

Keysight Technologies N5251A PNA Series 2-Port and 4-Port Microwave Network Analyzer System (10 MHz - 110 GHz)

Use this manual in conjunction with the following documents:

PNA Series Network Analyzer Embedded Help System (viewable online at <http://na.support.keysight.com/pna>)

PNA Series Network Analyzer Installation and Quick Start Guide
Part Number E8356-90001

N5227A PNA Series Microwave Network Analyzer Service Guide
Part Number N5227-90001

N5261A and N5262A Millimeter Head Controller User's and Service Guide
Part Number: N5262-90001

Installation and
Service Guide

NOTICE: This document contains references to Agilent Technologies. Agilent's former Test and Measurement business has become Keysight Technologies. For more information, go to www.keysight.com.



WARRANTY STATEMENT

THE MATERIAL CONTAINED IN THIS DOCUMENT IS PROVIDED "AS IS," AND IS SUBJECT TO BEING CHANGED, WITHOUT NOTICE, IN FUTURE EDITIONS. FURTHER, TO THE MAXIMUM EXTENT PERMITTED BY APPLICABLE LAW, KEYSIGHT DISCLAIMS ALL WARRANTIES, EITHER EXPRESS OR IMPLIED WITH REGARD TO THIS MANUAL AND ANY INFORMATION CONTAINED HEREIN, INCLUDING BUT NOT LIMITED TO THE IMPLIED WARRANTIES OF MERCHANTABILITY AND FITNESS FOR A PARTICULAR PURPOSE. KEYSIGHT SHALL NOT BE LIABLE FOR ERRORS OR FOR INCIDENTAL OR CONSEQUENTIAL DAMAGES IN CONNECTION WITH THE FURNISHING, USE, OR PERFORMANCE OF THIS DOCUMENT OR ANY INFORMATION CONTAINED HEREIN. SHOULD KEYSIGHT AND THE USER HAVE A SEPARATE WRITTEN AGREEMENT WITH WARRANTY TERMS COVERING THE MATERIAL IN THIS DOCUMENT THAT CONFLICT WITH THESE TERMS, THE WARRANTY TERMS IN THE SEPARATE AGREEMENT WILL CONTROL.

DFARS/Restricted Rights Notice

If software is for use in the performance of a U.S. Government prime contract or subcontract, Software is delivered and licensed as "Commercial computer software" as defined in DFAR 252.227-7014 (June 1995), or as a "commercial item" as defined in FAR 2.101(a) or as "Restricted computer software" as defined in FAR 52.227-19 (June 1987) or any equivalent agency regulation or contract clause. Use, duplication or disclosure of Software is subject to Keysight Technologies' standard commercial license terms, and non-DOD Departments and Agencies of the U.S. Government will receive no greater than Restricted Rights as defined in FAR 52.227-19(c)(1-2) (June 1987). U.S. Government users will receive no greater than Limited Rights as defined in FAR 52.227-14 (June 1987) or DFAR 252.227-7015 (b)(2) (November 1995), as applicable in any technical data.

Certification

Keysight Technologies certifies that this product met its published specifications at the time of shipment from the factory. Keysight Technologies further certifies that its calibration measurements are traceable to the United States National Institute of Standards and Technology, to the extent allowed by the Institute's calibration facility, and to the calibration facilities of other International Standards Organization members.

Assistance

Product maintenance agreements and other customer assistance agreements are available for Keysight Technologies products. For information about these agreements and for other assistance, contact Keysight. Refer to ["Contacting Keysight" on page 5-4.](#)

Safety and Regulatory Information

The safety and regulatory information pertaining to this product is located in [Chapter 1, "Safety and Regulatory Information"](#).

Safety Notes

The following safety notes are used throughout this manual. Familiarize yourself with each of the notes and its meaning before operating this instrument. All pertinent safety notes for using this product are located in [Chapter 1, "Safety and Regulatory Information"](#).

WARNING **Warning denotes a hazard. It calls attention to a procedure which, if not correctly performed or adhered to, could result in injury or loss of life. Do not proceed beyond a warning note until the indicated conditions are fully understood and met.**

CAUTION Caution denotes a hazard. It calls attention to a procedure that, if not correctly performed or adhered to, could result in damage to or destruction of the instrument. Do not proceed beyond a caution sign until the indicated conditions are fully understood and met.

Printing Copies of Documentation from the Web

To print copies of documentation from the Web, download the PDF file from the Keysight web site:

- Go to <http://www.keysight.com>.
- Enter the document's part number (located on the title page) in the **Search** box.
- Click **Search**.
- Click the appropriate hyperlink to view the document PDF.
- Print the document.

Contents

1 Safety and Regulatory Information

Safety Symbols	1-2
General Safety Considerations	1-2
Safety Earth Ground	1-2
Before Applying Power	1-2
Servicing	1-2
Electrostatic Discharge Protection	1-4
Regulatory Information	1-5
Instrument Markings	1-6
Lithium Battery Disposal	1-7

2 System Description

N5251A Network Analyzer System	2-2
Options	2-3
Basic System Measurement Configurations	2-4
Coaxial Measurement	2-4
Wafer Probe Measurement	2-5
N5261A and N5262A Millimeter Head Controllers	2-6
Millimeter-Wave Test Head Modules	2-7
Theory of Operation	2-8

3 System Installation

Receiving the System	3-2
The System as Shipped	3-2
Keysight Technologies Customer Engineering	3-2
System Contents	3-3
Site Preparation	3-5
Power Requirements	3-5
Environmental Requirements	3-6
Protect Against Electrostatic Discharge (ESD)	3-7
Review the Principles of Connector Care	3-7
Space Requirements	3-7
PNA, Controller, and Test Head Module Interconnections	3-9
Mount PNA on Top of Controller	3-9
Rear Panel Cabling	3-9
Front Panel Cabling	3-11
Configuring the PNA Software for the N5251A	3-15

4 System Specifications

Specifications	4-2
System Specifications (typical)	4-2
N5227A Rear Panel Specifications	4-4
N5251A Test Head Bias-Tees Specifications	4-4
Test Head Module Dimensions	4-6

5 Maintenance and Support

Maintenance	5-2
Physical Maintenance	5-2

Contents

Electrical Maintenance	5-2
Caring for Waveguide (WG) Interfaces	5-2
Principles of Connector Care	5-3
Keysight Support, Services, and Assistance	5-4
Service and Support Options	5-4
Contacting Keysight	5-4
Shipping an Item to Keysight for Service or Repair	5-4
6 Performance Tests and Checks	
System Preparation and Analyzer Warm Up	6-2
Torquing Connections	6-2
Long Term Storage of Test Results	6-2
Protect Against Electrostatic Discharge (ESD)	6-2
Review the Principles of Connector Care	6-3
System Check	6-4
System Performance Verification	6-6
When to Verify	6-6
Materials Required	6-7
General Preparation	6-7
Verification Procedure	6-8
Verification Results Files	6-11
Interpreting the Verification Results	6-15
Improving the Verification Results	6-16
Saving Verification Results	6-16
7 Replaceable Parts	
Ordering Information	7-2
Replaceable Parts	7-3

1 Safety and Regulatory Information

Safety Symbols

The following safety symbols are used throughout this manual. Familiarize yourself with each of the symbols and its meaning before operating this instrument.

CAUTION Caution denotes a hazard. It calls attention to a procedure that, if not correctly performed or adhered to, could result in damage to or destruction of the instrument. Do not proceed beyond a caution note until the indicated conditions are fully understood and met.

WARNING Warning denotes a hazard. It calls attention to a procedure which, if not correctly performed or adhered to, could result in injury or loss of life. Do not proceed beyond a warning note until the indicated conditions are fully understood and met.

General Safety Considerations

Safety Earth Ground

WARNING This is a Safety Class I product (provided with a protective earthing ground incorporated in the power cord). The mains plug shall only be inserted in a socket outlet provided with a protective earth contact. Any interruption of the protective conductor, inside or outside of the instrument, will make the instrument dangerous. Intentional interruption is prohibited.

CAUTION Always use the three-prong AC power cord supplied with this product. Failure to ensure adequate grounding by not using this cord may cause product damage.

Before Applying Power

CAUTION Make sure that the analyzer line voltage selector switch is set to the voltage of the power supply and the correct fuse is installed.

CAUTION If this product is to be energized via an autotransformer make sure the common terminal is connected to the neutral (grounded side of the mains supply).

CAUTION This product is designed for use in Installation Category II and Pollution Degree 2.

Servicing

WARNING These servicing instructions are for use by qualified personnel only. To avoid electrical shock, do not perform any servicing unless you are qualified to do so.

WARNING The opening of covers or removal of parts may expose dangerous voltages. Disconnect the instrument from all voltage sources while it is opened.

WARNING Danger of explosion if battery is incorrectly replaced. Replace only with the same or equivalent type recommended. Discard used batteries according to manufacturer's instructions.

WARNING Procedures described in this document may be performed with power supplied to the product while protective covers are removed. Energy available at many points may, if contacted, result in personal injury.

WARNING The power cord is connected to internal capacitors that may remain live for 10 seconds after disconnecting the plug from its power supply.

WARNING For continued protection against fire hazard, replace line fuse only with same type and rating. The use of other fuses or material is prohibited.

WARNING The detachable power cord is the instrument disconnecting device. It disconnects the mains circuits from the mains supply before other parts of the instrument. The front panel switch is only a standby switch and is not a LINE switch (disconnecting device).

Electrostatic Discharge Protection

Protection against electrostatic discharge (ESD) is essential while removing assemblies from or connecting cables to the system components. Static electricity can build up on your body and can easily damage sensitive internal circuit elements when discharged. Static discharges too small to be felt can cause permanent damage. To prevent damage to the instrument:

- *always* have a grounded, conductive table mat in front of your test equipment.
- *always* wear a grounded wrist strap, connected to a grounded conductive table mat, having a 1 M Ω resistor in series with it, when handling components and assemblies or when making connections.
- *always* wear a heel strap when working in an area with a conductive floor. If you are uncertain about the conductivity of your floor, wear a heel strap.
- *always* ground yourself before you clean, inspect, or make a connection to a static-sensitive device or test port. You can, for example, grasp the grounded outer shell of the test port or cable connector briefly.
- *always* ground the center conductor of a test cable before making a connection to the analyzer test port or other static-sensitive device. This can be done as follows:
 1. Connect a short (from your calibration kit) to one end of the cable to short the center conductor to the outer conductor.
 2. While wearing a grounded wrist strap, grasp the outer shell of the cable connector.
 3. Connect the other end of the cable to the test port and remove the short from the cable.

Figure 1-1 shows a typical ESD protection setup using a grounded mat and wrist strap.

Figure 1-1 ESD Protection Setup

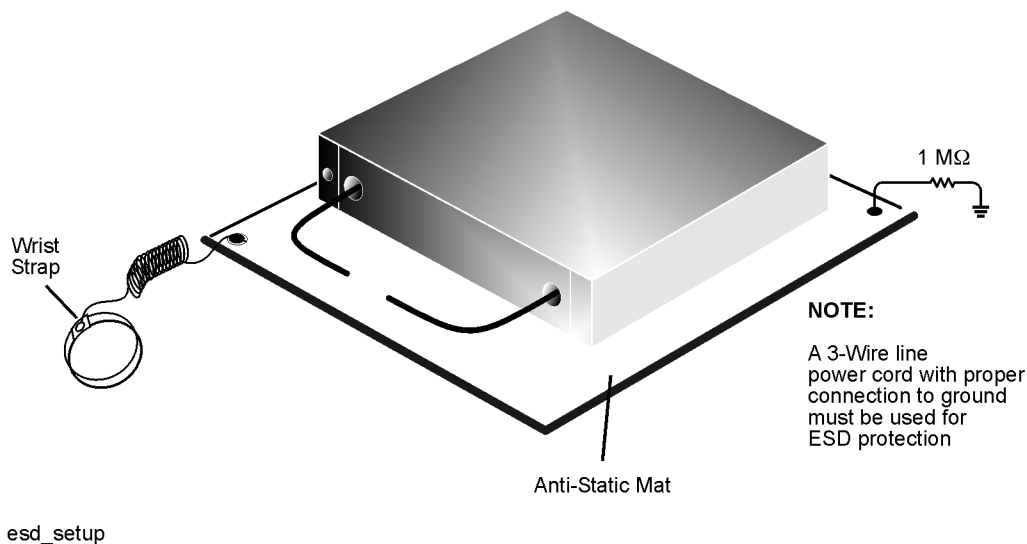

Regulatory Information

This section contains information that is required by various government regulatory agencies.

Instrument Markings



The instruction documentation symbol. The product is marked with this symbol when it is necessary for the user to refer to the instructions in the documentation.



The AC symbol indicates the required nature of the line module input power.



This symbol indicates separate collection for electrical and electronic equipment, mandated under EU law as of August 13, 2005. All electrical and electronic equipment are required to be separated from normal waste for disposal (Reference WEEE Directive, 2002/96/EC).



This symbol indicates that the power line switch is ON.



This symbol indicates that the power line switch is in the STANDBY position.



This symbol indicates that the power line switch is in the OFF position.



This symbol is used to identify a terminal which is internally connected to the product frame or chassis.



The CE mark is a registered trademark of the European Community. (If accompanied by a year, it is when the design was proven.)



The CSA mark is a registered trademark of the CSA International.



This mark designates the product is an Industrial Scientific and Medical Group 1 Class A product (reference CISPR 11, Clause 5).



This is a marking to indicate product compliance with the Canadian Interference-Causing Equipment Standard (ICES-001).



Direct current.



The instrument has been designed to meet the requirements of IP 2 0 for ingress and operational environment.



The RCM mark is a registered trademark of the Australian Communications and Media Authority.



Indicates the time period during which no hazardous or toxic substance elements are expected to leak or deteriorate during normal use. Forty years is the expected useful life of the product.



This symbol on all primary or secondary packaging indicates compliance to China standard GB 18455-2001.



South Korean Certification (KC) mark; includes the marking's identifier code which follows the format: MSIP-REM-YYY-ZZZZZZZZZZZZZZ or KCC-REM-YYY-ZZZZZZZZZZZZ.

Lithium Battery Disposal

If the battery on the network analyzer's CPU board needs to be disposed of, dispose of it in accordance with your country's requirements. If required, you may return the battery to Keysight Technologies for disposal. For assistance refer to ["Contacting Keysight" on page 5-4](#).



**DO NOT THROW BATTERIES AWAY BUT
COLLECT AS SMALL CHEMICAL WASTE.**

2 System Description

N5251A Network Analyzer System

The N5251A is a 2-port or 4-port vector network analyzer system with an extremely wide frequency range of 10 MHz to 110 GHz. The N5251A uses the same 1.0 mm test port connections throughout its entire range of test frequencies. It is never necessary to make and break connections to complete a test.

The illustration below shows the N5251A configured for coaxial measurement. The system can also be configured for on-wafer measurement using a wafer probe test station.

Figure 2-1 N5251A 4-Port System

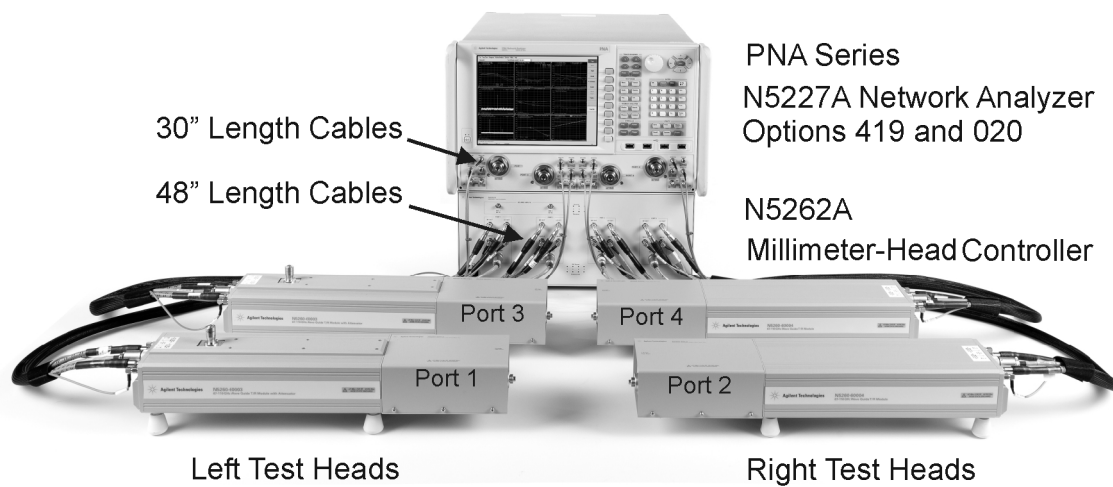

N5251_001_204

Options

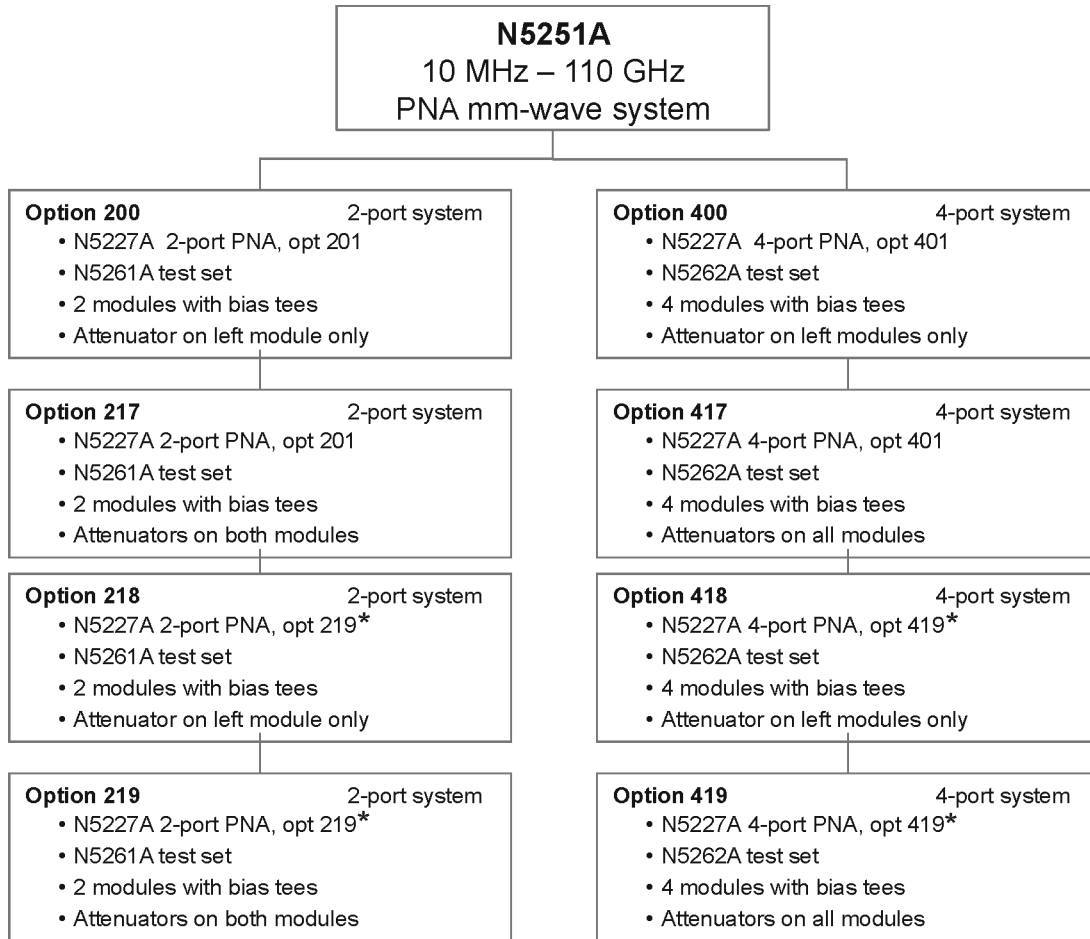

* Options 219 and 419 add source and receiver attenuators to the PNA.

N5251_001_202

Basic System Measurement Configurations

The N5251A can be used in either of two basic configurations, depending on how the test ports are connected to the device under test (DUT): coaxial measurement configuration or wafer probe measurement configuration.

CAUTION Input power to the test ports must not exceed +27 dBm. Input power in excess of this level will damage expensive components. Observe proper precautions, especially when measuring amplifiers with gains of 20 dB or greater.

Coaxial Measurement

This configuration is used when the DUT has coaxial connectors. The N5251A test ports have 1.0 mm coaxial connectors, and are designed to cover a frequency range of 10 MHz to 110 GHz.

In this configuration, the test head modules are placed on a work bench in front of the millimeter head controller.

The DUT is normally connected to the test ports by way of a 1.0 mm coaxial cable (test port cable). Connect the DUT to Port 1 (left test head module) directly, and to Port 2 (right test head module) by way of a test cable. It is also possible to connect the DUT using a test port cable on each test port, although this configuration will result in greater signal loss.

CAUTION Do not attempt to connect a test device directly between the two 1.0 mm test ports, without at least one test port cable. The test head modules will not move freely enough to allow such a connection to be made safely.

Figure 2-2 on page 2-5 shows how the instruments are configured on a work bench for the coaxial measurement configuration. The test head modules are placed on the bench top in front of the PNA and controller.

Figure 2-2 Coaxial Measurement Configuration, 2-Port System

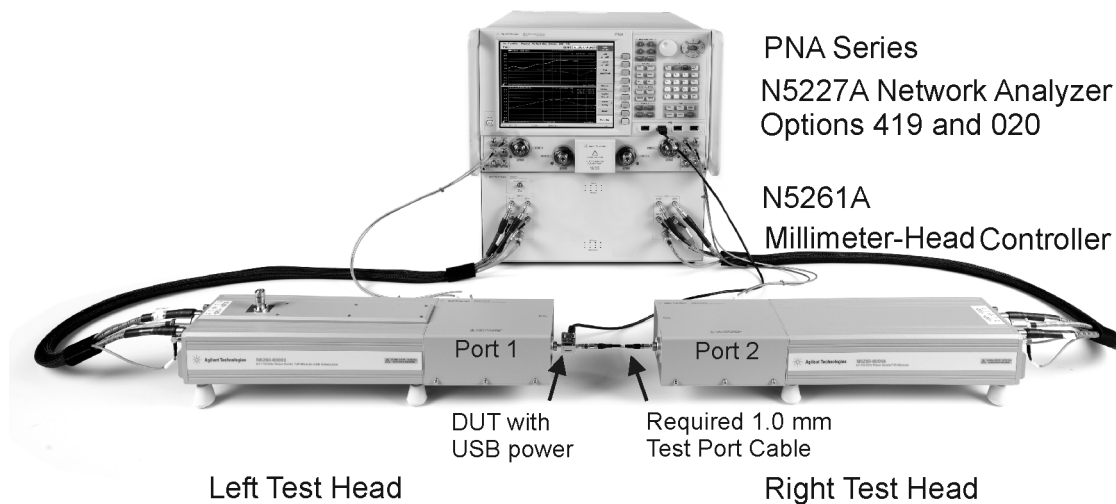

N5251_001_205

Wafer Probe Measurement

In this configuration, the test head modules are placed on X-Y-Z positioners that are mounted to the wafer probe station. Each 1.0 mm test port is directly connected to a wafer probe assembly via a coaxial cable.

NOTE The wafer probe measurement configuration is not documented in this manual.

For information about probing equipment and accessories, contact:

Cascade Microtech, Inc.
9100 SW Gemini Drive
Beaverton, Oregon 97008, USA
Toll-free telephone: (800) 550-3279

Telephone: (503) 601-1000
Web site www.cascademicrotech.com

For additional information on DUT bias connections, refer to [Table 4-4 on page 4-4](#), [Figure 4-1 on page 4-5](#), and [Figure 4-2 on page 4-6](#).

N5261A and N5262A Millimeter Head Controllers

The N5261A and N5262A millimeter head controllers provide the test interface between the millimeter-wave test head modules and the N5227A PNA series network analyzer.

The millimeter head controller, when used in conjunction with the millimeter-wave test head modules and the PNA, provides all of the feature and functions of a full S-Parameter test set.

The millimeter head controller supplies RF and LO signals to the millimeter-wave test head modules and returns the down converted reference and test IF signals to the PNA for processing and display. The N5261A and N5262A millimeter head controllers also supply the +12 volt bias to each millimeter-wave head module.

The front panels of the N5261A and N5262A millimeter head controllers are illustrated below.

For additional information, see the N5261A and N5262A User's and Service Guide. If a printed version of the manual is not available, refer to ["Printing Copies of Documentation from the Web"](#) on page iii of this manual.

Figure 2-3 N5261A Millimeter Head Controller Front Panel

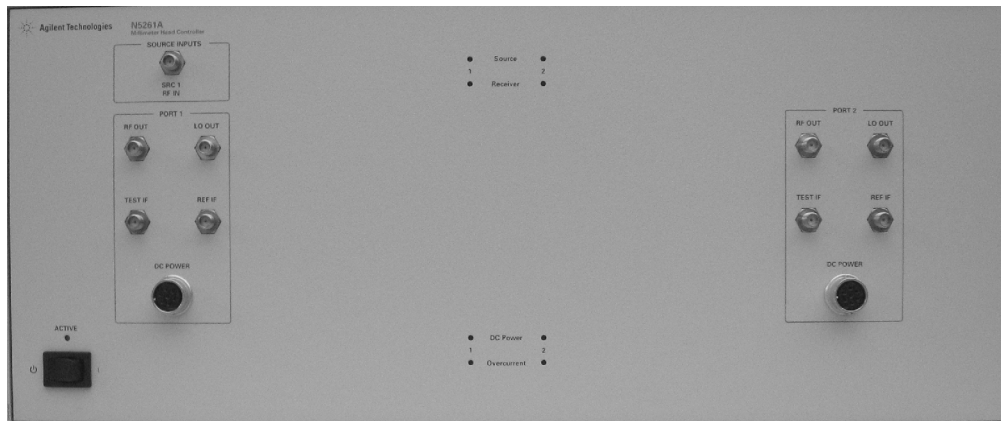

N5250_001_321

Figure 2-4. N5262A Millimeter Head Controller Front Panel

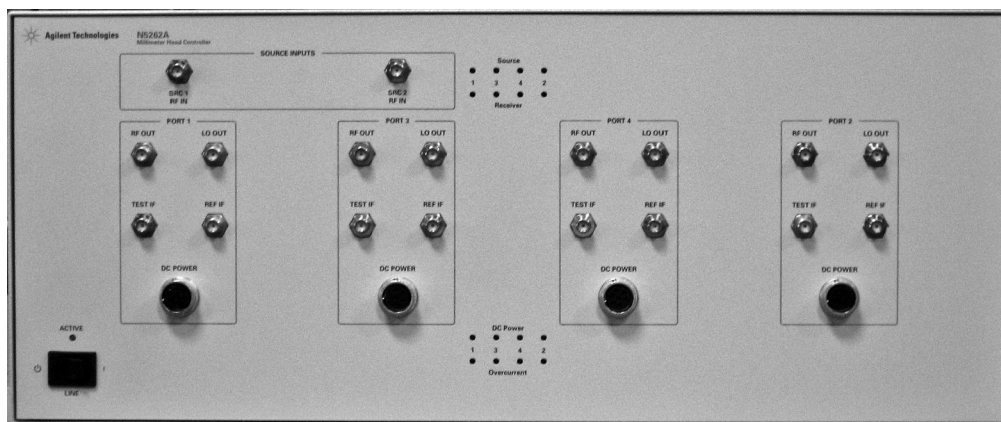

n5250_001_309

Millimeter-Wave Test Head Modules

A pair of 67-110 GHz millimeter-wave test head modules, in conjunction with the N5261A or N5262A millimeter head controller, is used to make reflection, transmission, or S-parameter measurements at millimeter wave frequencies with the N5227A PNA. These test head modules are manufactured by OLM, Inc.©

The N5251A system measurement ports, Port 1 and Port 2, are in the left and right millimeter-wave test head modules, respectively.

The left and right test head modules are illustrated in **Figure 2-5 on page 2-7**. Each test head consists of a combiner assembly and a waveguide module. The combiner assembly contains a coupler and combiner, and a bias-tee. The multiple-connector panels provide connections between the test head module, the N5261A or N5262A millimeter head controller, and the N5227A PNA.

Figure 2-5 Left and Right Frequency Extender Test Head Modules

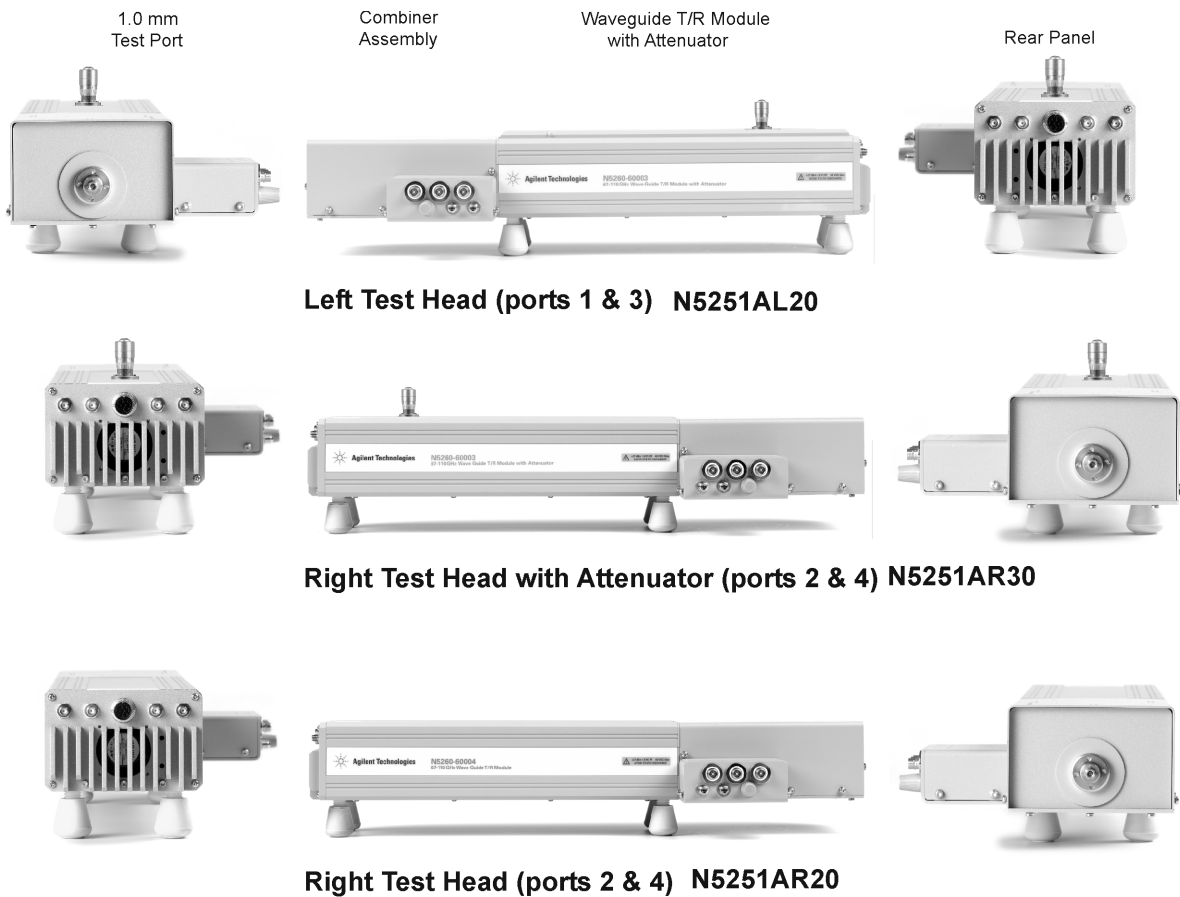

N5251_001_201

Theory of Operation

Refer to the block diagram in [Figure 2-6 on page 2-9](#) for the following paragraphs.

The N5261A or N5262A millimeter head controller routes the LO and RF signals from the N5227A PNA to the test set modules. The millimeter head controller also performs switching from Port 1 to Port 2. The test head modules separate the incident from the reflected RF signal and then down convert those signals to an IF signal.

The test head modules do not have their own power supplies; each head receives dc power from the N5261A or N5262A millimeter head controller, by way of a multi-pin interface cable.

10 MHz to 67 GHz Operation

The RF signal from the N5227A PNA SOURCE OUT is input into the SOURCE OUT connector of the combiner module. The RF signal is then input to the bias tee and then the coupler. From the coupler, the RF signal passes through the combiner and then to the test port.

The signal received at the test port of the combiner (either transmitted from another test head module or reflected from a device under test) is routed to the RCVR connector via the combiner and coupled arm of the coupler. This output goes to the RCVR IN connector on the appropriate port of the N5227A PNA.

67 GHz to 110 GHz Operation

The RF signal is received from the N5261A or N5262A millimeter head controller and input into the RF IN connector of the T/R millimeter module. The RF is then amplified and multiplied times six by the source multiplier. This multiplied incident RF signal then passes through micrometer, attenuator (optional), and a dual directional coupler where a portion of it is coupled off into the reference mixer.

The signal received at the test port of the combiner section (either transmitted from another test head module or reflected from a device under test) is routed back to the dual directional coupler in the T/R millimeter module where a portion of it is coupled off into the test mixer.

The LO signal is input from the N5227A PNA through the N5261A or N5262A millimeter head controller. The harmonic mixers combine the 8th harmonic of the LO with the test or the reference signals to produce the Test IF and Ref IF signals. The IF signals are passed to the N5227A PNA for further processing.

Figure 2-6 Millimeter-wave Test Head Module Block Diagram

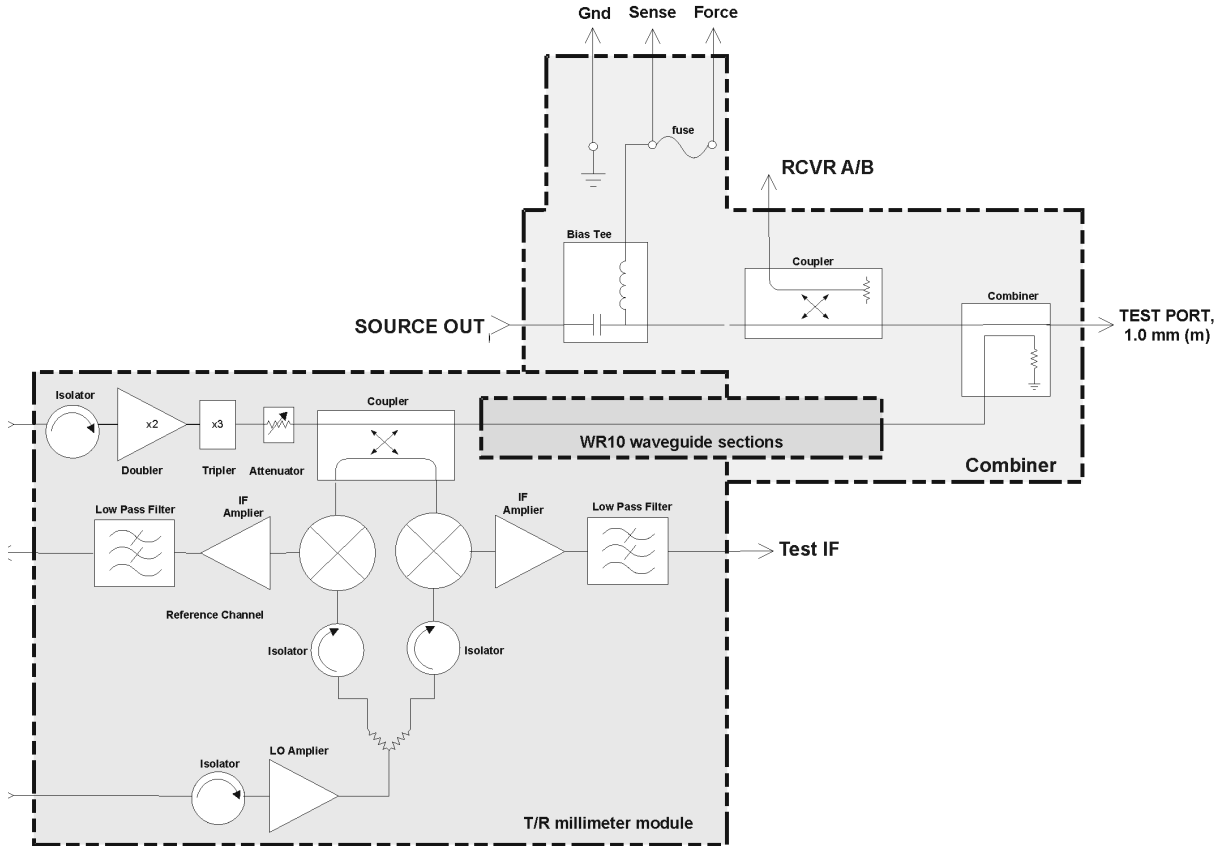

N5251_001_203

3 System Installation

Receiving the System

WARNING The N5261A and N5262A millimeter head controllers and the test head modules are sensitive to electrostatic discharge (ESD). Ground your work station before unpacking and installing the test head modules. See **“Electrostatic Discharge Protection” on page 1-4.**

The System as Shipped

The N5251A system components will arrive packaged separately. For a complete list of components shipped with your system, refer to [Table 3-1 on page 3-3](#) and [Table 3-2 on page 3-4](#).

When the entire shipment has arrived, contact Keysight Technologies to arrange for system installation. See [“Keysight Support, Services, and Assistance” on page 5-4](#).

Keep the shipping containers until the system checklist has been completed, and the system has been checked for physical damage.

If the shipping container is damaged or the packaging material shows signs of stress, notify the carrier as well as Keysight Technologies. Keep the shipping materials for the carrier’s inspection. Keysight Technologies will arrange for repair or replacement of damaged equipment without waiting for a claim settlement from the carrier. Refer to [“Keysight Support, Services, and Assistance” on page 5-4](#).

Keysight Technologies Customer Engineering

An Keysight Technologies Customer Engineer will be assigned to help you install the system. During installation, the Customer Engineer will do the following:

- Unpack the system components.
- Complete the system checklist, see [Table 3-1 on page 3-3](#) and [Table 3-2 on page 3-4](#).
- Connect the N5227A PNA and the N5261A or N5262A millimeter head controller.
- Install the millimeter-wave test head modules.
- Run a performance verification of the system, which includes a measurement calibration.
- Provide training for one user.

System Contents

Use the table below to verify that the shipment is complete. These are items that are supplied with all complete N5251A systems. A complete system is shipped in multiple containers. Be sure to open all containers when verifying that every system component has been received.

Table 3-1 N5221A System Contents (Table 1 of 2)

Contents	N5221A System							
	Option 200	Option 217	Option 218	Option 219	Option 400	Option 417	Option 418	Option 419
N5227A 2-Port PNA, Option 201	1	1	--	--	--	--	--	--
N5227A 2-Port PNA, Option 219	--	--	1	1	--	--	--	--
N5227A 4-Port PNA, Option 401	--	--	--	--	1	1	--	--
N5227A 4-Port PNA, Option 419	--	--	--	--	--	--	1	1
Left Module (with attenuator)	1	1	1	1	2	2	2	2
Right Module, (without attenuator)	1	--	1	--	2	--	2	--
Right Module, (with attenuator)	--	1	--	1	--	2	--	2
N5261A Test Set Controller	1	1	1	1	--	--	--	--
N5262A Test Set Controller	--	--	--	--	1	1	1	1

NOTE All N5227A PNA models must have option 020 in addition to the 201, 219, 401, or 419 indicated in these tables.

Table 3-2 N5221A System Contents (Table 2 of 2)

Contents	N5221A System							
	Option 200	Option 217	Option 218	Option 219	Option 400	Option 417	Option 418	Option 419
Right-angle adapters 1250-2604	4	4	4	4	8	8	8	8
Cable assy 5061-9038	6	6	6	6	8	8	8	8
PNA to N5261/2A cable 8120-6818	1	1	1	1	1	1	1	1
DC bias cable 85105-60030 (48")	2	2	2	2	4	4	4	4
SMA cable with right-angle connectors 85105-60033 (48")	4	4	4	4	8	8	8	8
3.5 mm cable, straight connectors 8121-1221 (48")	4	4	4	4	8	8	8	8
1.85 mm cable 8121-1233 (30")	4	4	4	4	8	8	8	8
Cable dressing & label kit N5261-60019	2	2	2	2	4	4	4	4
Lock link kit U3021-60003	1	1	1	1	1	1	1	1
N5261/62A User's and Service Guide N5262-90001	1	1	1	1	1	1	1	1

Site Preparation

Power Requirements

Before installing the system, be sure that the required ac power is available at all necessary locations.

- Three-wire power cables (which provide a safety ground) must be used with all instruments.
- Air-conditioning equipment (or other motor-operated equipment) should not be placed on the same ac line that powers the system.
- The table below lists the maximum VA ratings and BTU/hour ratings for all instruments in the system. This table can be used to determine both the electrical requirements and the air conditioning requirements of the system.

Table 3-3 Power Requirements of the System

Standard Equipment		
Instrument	Maximum VA Rating	Maximum BTU/hour
N5227A	350	1195
N5261A or N5262A millimeter head controller	320	1095
N5260-60007 left test head module or N5260-60006 right test head module	(powered from controller)	(powered from controller)
N5260-60011 left test head module or N5260-60010 right test head module	(powered from controller)	(powered from controller)
N5260-60011 left test head module or N5260-60022 right test head module	(powered from controller)	(powered from controller)
Total	670	2290

Notes:

- (1) Values are based on 120 Vac supplied to each instrument at 60 Hz.
- (2) The N5261A or N5262A millimeter head controller supplies power to the test head modules.

Environmental Requirements

The environmental requirements shown below are characteristic for the system and are based on the limitations of the N5227A network analyzer used.

Table 3-4 Environmental Requirements

Temperature	
Operation	5 °C to 40 °C (41 °F to 104 °F)
Storage	–40 °C to +65 °C (–40 °F to +158 °F)
Measurement Calibration	20 °C to 26 °C (68 °F to 79 °F)
Performance Verification	Temperature must be within 1 °C (1.8 °F) of the temperature at which the measurement calibration was performed.
Relative Humidity	Type tested at 95%, +40 °C (non-condensing)
Pressure Altitude	Type tested 0 to 4600 meters (~15,000 feet)

System Heating and Cooling

Install air conditioning and heating, if necessary, to maintain the ambient temperature within the appropriate range (as given in the table above). Air conditioning capacity must be consistent with the BTU ratings given in [Table 3-3 on page 3-5](#).

Required Conditions for Accuracy Enhanced Measurement

Accuracy-enhanced (error-corrected) measurements require the ambient temperature of the N5251A to be maintained within ± 1 °C of the ambient temperature at calibration.

Protect Against Electrostatic Discharge (ESD)

This is important. If not properly protected against, electrostatic discharge can seriously damage your analyzer, resulting in costly repair.

CAUTION To reduce the chance of electrostatic discharge, follow all of the recommendations outlined in [“Electrostatic Discharge Protection” on page 1-4](#).

Review the Principles of Connector Care

Proper connector care and connection techniques are critical for accurate and repeatable measurements. Refer to [Table 5-1 on page 5-3](#) for tips on connector care.

Prior to making connections to your analyzer, carefully review the information about inspecting, cleaning, and gaging connectors. Refer to the calibration kit documentation for detailed connector care information.

Space Requirements

Standard installation of the N5251A system includes configuration and installation of the system on a customer provided lab bench or table top of adequate size and strength.

N5251A System Weight and Dimensions

Model	Weight	Required Benchttop Dimensions for the System		
		Clearance	Width	Depth
2-Port	60.1 kg (132 lb)	48 cm (19 in)	178 cm (70 in)	114 cm (45 in)
4-Port	83.5 kg (183.2 lb)	48 cm (19 in)	178 cm (70 in)	140 cm (55 in)

Component Weight and Dimensions

[Table 3-5](#) shows the maximum weight and dimensions of the N5251A system components. Refer also to [Figure 4-3. on page 4-7](#) for test head module dimensions.

Table 3-5 N5251A System Components Weights and Dimensions

Model	Weight	Height	Width	Depth
Millimeter-wave test head module (each)	3.5 kg (7.5 lb, ± 0.5 lb)	6.9 cm (2.7 in)	50.7 cm (20 in)	17.8 cm (6.9 in)
N5227A, 2-Port PNA, Option 201 or 219	42.2 kg (93 lb) nominal	27.91 cm (11.0 in)	48.29 cm (19.0 in)	64.96 cm (25.6 in)
N5227A, 4-Port PNA, Option 401 or 419	44.9 kg (99 lb) nominal			
N5261A millimeter- head controller	10.0 kg (22 lb)	18.0 cm (7.1 in)	42.5 cm (16.75 in)	42.5 cm (16.75 in)
N5262A millimeter- head controller	11.0 kg (24.2 lb)	18.0 cm (7.1 in)	42.5 cm (16.75 in)	42.5 cm (16.75 in)

PNA, Controller, and Test Head Module Interconnections

Mount PNA on Top of Controller

Mount the PNA on top of the N5261/2A controller as shown in [Figure 3-1 on page 3-10](#) and [Figure 3-2 on page 3-11](#). Use the Lock Link kit (U3021-60003) to mechanically connect the two units. Detailed instructions are contained in the “System Configuration and Operation” section of the N5261A and N5262A User’s and Service Guide (N5262-90001).

Rear Panel Cabling

[Figure 3-1 on page 3-10](#) and [Figure 3-2 on page 3-11](#) illustrate the rear panel cabling for 2-port and 4-port systems. Torque all RF connections to 8 in-lbs (0.90 N.m) to insure proper connection.

Figure 3-1 2-Port Model Rear Panel Cabling

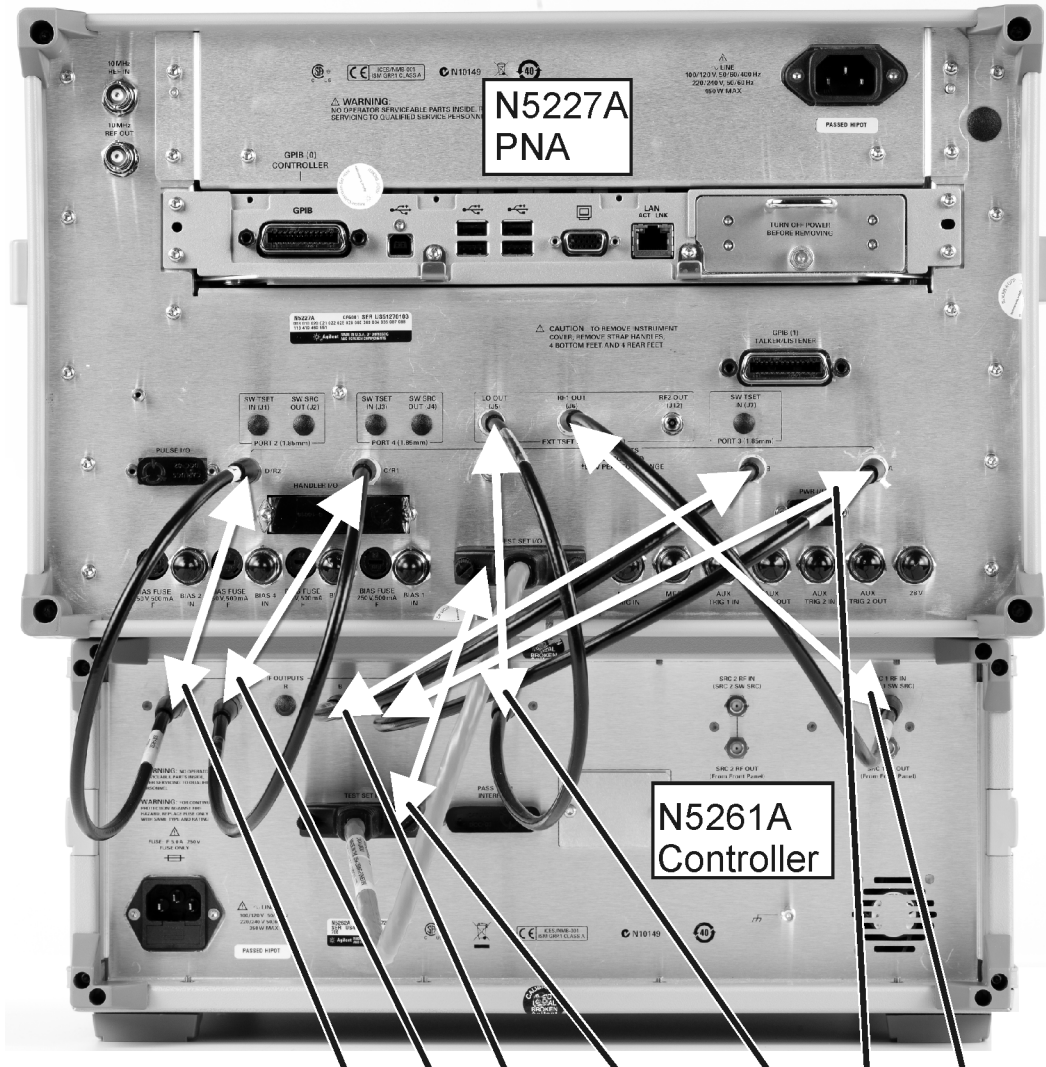

N5227A PNA	D/R2	C/R1	B	TEST SET I/O	LO OUT	A	RF1 OUT
N5261A Controller	D	C	B	TEST SET I/O	LO IN	A	SRC1 IN

N5251_001_306

NOTE Cables shown in the graphic above are the same (5061-9038) except for the Test Set I/O cable (8120-6818).

Figure 3-2 4-Port Model Rear Panel Cabling

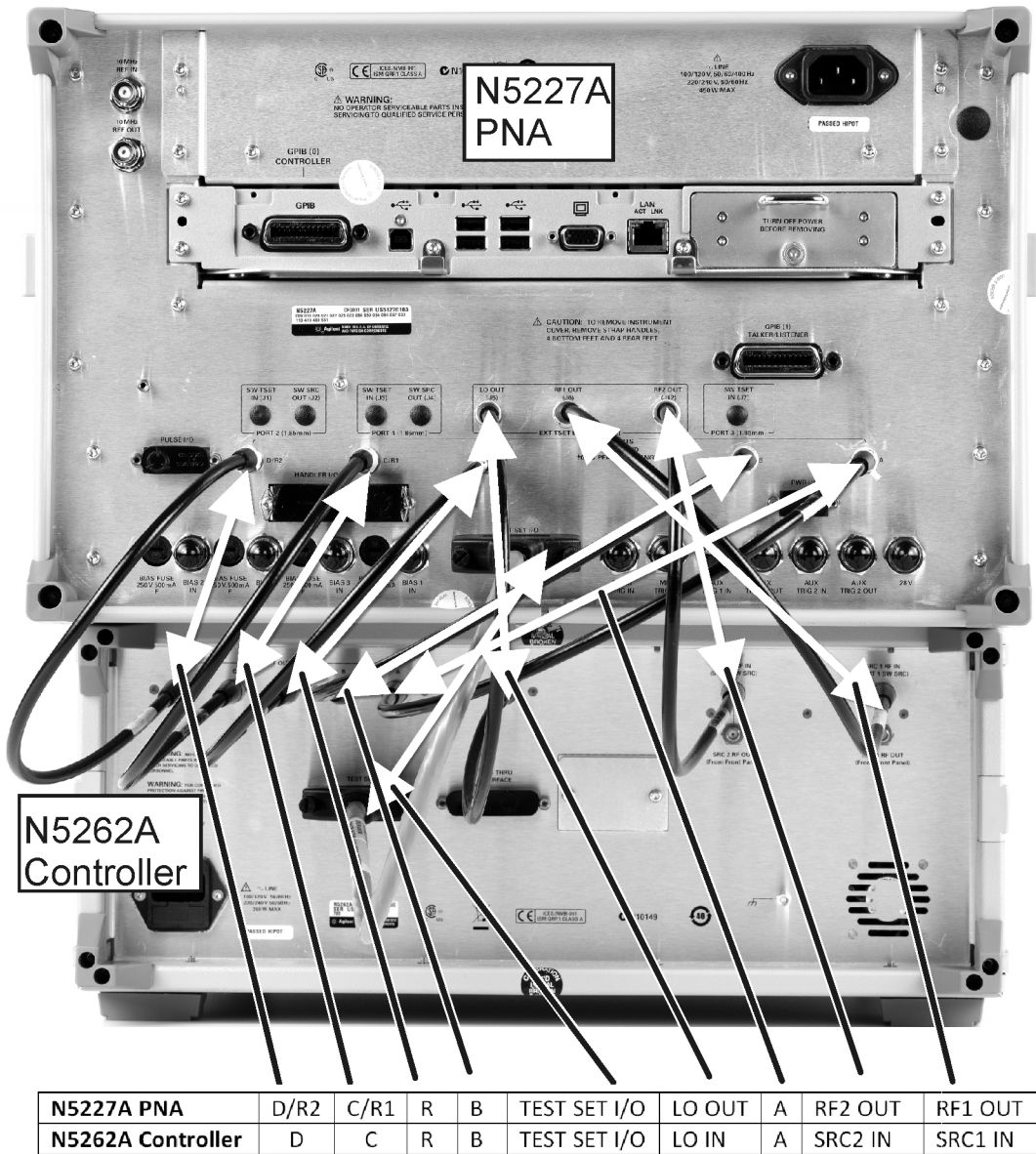

N5251_001_307

NOTE Cables shown in the graphic above are the same (5061-9038) except for the Test Set I/O cable (8120-6818).

Front Panel Cabling

The front-panel connections between the millimeter head controller and a test head module are shown in **Figure 3-3**. This cabling is duplicated for each test head module in the system.

Figure 3-3 Cable Connections for Single Test Head Module

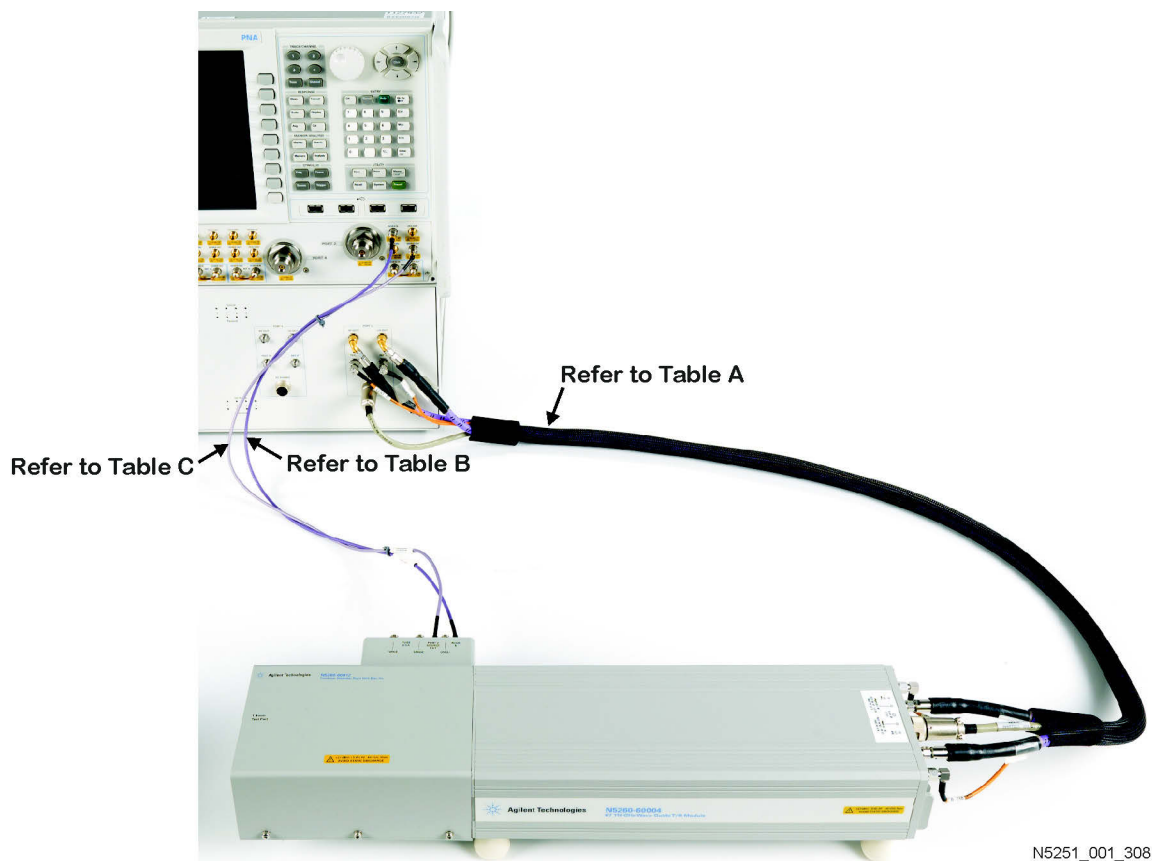

N5251_001_308

Table A

Table B

Table C

N5261/2A	N5250CX10	Cable Part Number	PNA Front Panel	N5250CX10	PNA Front Panel	N5250CX10
RF OUT	R.F. In	8121-1221	RCVR A IN (PORT 1)	RCVR A	SOURCE OUT (PORT 1)	PORT 1 SOURCE OUT
LO OUT	L.O. In	8121-1221	RCVR B IN (PORT 2)	RCVR B	SOURCE OUT (PORT 2)	PORT 2 SOURCE OUT
TEST IF	Test I.F.	85105-60033	RCVR C IN (PORT 3)	RCVR A	SOURCE OUT (PORT 3)	PORT 1 SOURCE OUT
REF IF	Ref I.F.	85105-60033	RCVR D IN (PORT 4)	RCVR B	SOURCE OUT (PORT 4)	PORT 2 SOURCE OUT
DC POWER	+12 V	85105-60030	1.85 mm cable 8121-1233			

Connections For Each Head

1. Prepare a cable bundle comprised of the five cables in Table A. For instructions, refer to steps 1 through 5 of the Installation Guide from the Millimeter-wave Cable Dress kit (document part number N5260-90070 contained in kit part number N5261-60019). **DO NOT APPLY THE VELCRO FASTENERS AROUND THE CABLES AT THIS TIME.**
2. Connect the five cables to the front panel of the controller, using two upright angle adaptors (1260-2604). Details are illustrated in [Figure 3-4](#).

Recommended order of connection:

- DC POWER
 - TEST IF
 - REF IF
 - RF OUT
 - LO OUT
3. Torque all cable connectors to 8 in-lbs (0.90 N.m).

Figure 3-4 Details for Controller Front Panel Connections

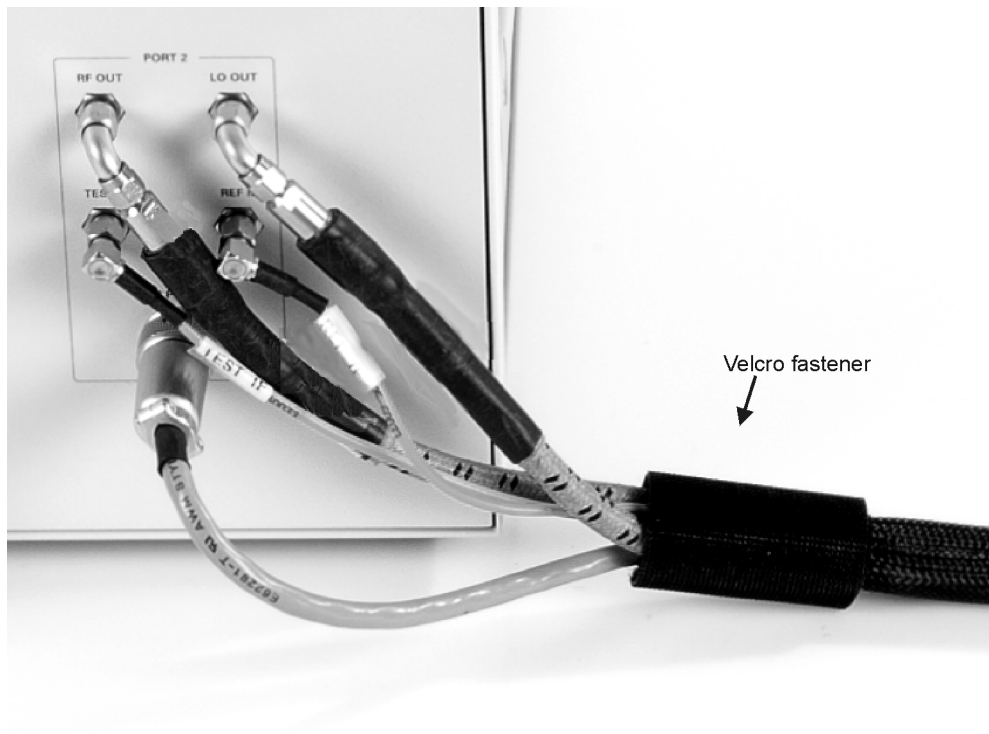

N5251_001_309

4. Select a test head module to connect to the port. The test head module depends on the port number. Refer to [Figure 2-5 on page 2-7](#).
5. Place the test head module on the work surface in front of the controller.

6. Connect the five cables to the test head module. Details are illustrated in [Figure 3-5](#).

Recommended order of connection:

- +12 V
- R.F. In
- L.O. In
- Ref I.F.
- Test I.F.

7. Torque all cable connectors to 8 in-lbs (0.90 N.m).

Figure 3-5 Details for Test Head Module Connections

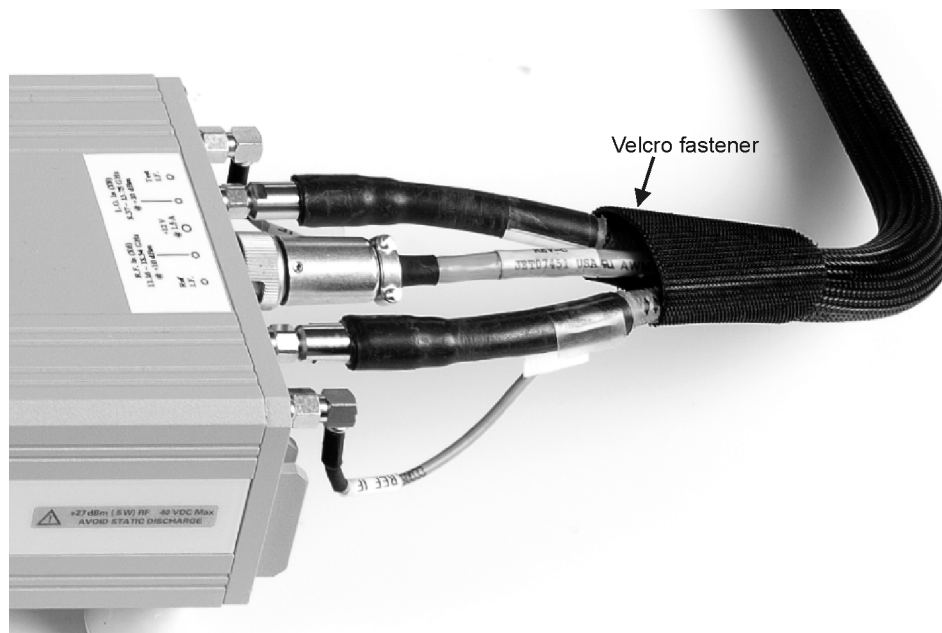

N5251_001_310

8. Apply Velcro fasteners to the ends of the cable sleeve as shown in [Figure 3-4](#) and [Figure 3-5](#). For instructions, refer to steps 6 through 8 of the Installation Guide from the Millimeter-wave Cable Dress kit (document part number N5260-90070 contained in kit part number N5261-60019).

9. Position the test head module in the approximate location where it will be used for measurement operation.

10. Connect two cables with 1.85 mm connectors (8121-1233) between the front panel of the PNA and the test head modules. Details are shown in [Figure 3-2 on page 3-11](#).

11. Torque all cable connectors to 8 in-lbs (0.90 N.m).

12. Connect mini-triax cables, as needed, for bias power to the DUT.

Configuring the PNA Software for the N5251A

1. On the PNA, select: **Utility > System > Configure > Millimeter Module Configuration**. The dialog box shown in the following figure will be displayed.

Figure 3-6 Millimeter Module Configuration Dialog Box

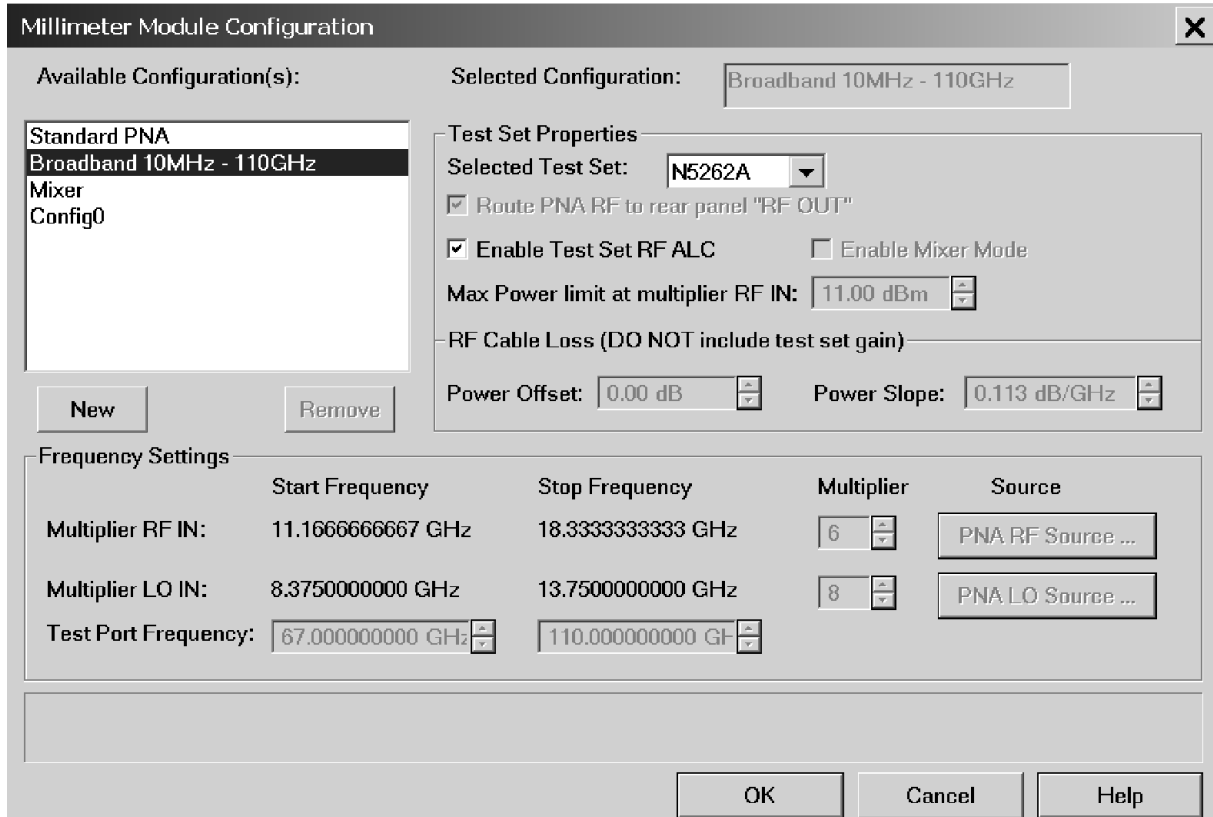

N5251_001_311

2. On the dialog box, under Available Configuration(s), select **Broadband 10MHz - 110GHz**.
3. Select the appropriate test set.
4. Select the checkbox **Enable Test Set RF ALC**.
5. Click **OK**. This activates the N5251A mode for the PNA.

NOTE To activate stand-alone PNA operation, select **Standard PNA** and click **OK**.

4 System Specifications

Specifications

System Specifications (typical)

The N5251A system has typical (non-warranted) specifications only. See [Table 4-1](#).

Table 4-1 Typical System Specifications

Test Port Power (dBm)	1.0 mm Test Port (Std. ^a or Opt 017 or 018 ^b)	1.85 mm PNA Port	WR-10 Waveguide Port
10 MHz to 45 MHz	-8	-7	
45 MHz to 500 MHz	-3	-1	
500 MHz to 2 GHz	0	+2	
2 GHz to 10 GHz	-2	+2	
10 GHz to 24 GHz	-5	0	
24 GHz to 30 GHz	-7	0	
30 GHz to 40 GHz	-10	-1	
40 GHz to 45 GHz	-15	-5	
45 GHz to 50 GHz	-12	-1	
50 GHz to 60 GHz	-17	-4	
60 GHz to 67 GHz	-22	-8	
67 GHz to 70 GHz	-9		-2
70 GHz to 75 GHz	-7		0
75 GHz to 80 GHz	-6		+1
80 GHz to 100 GHz	-5		+1
100 GHz to 110 GHz	-8		-2
Noise Floor (dBm)	1.0 mm Test Port	1.85 mm PNA Port	Waveguide Port
10 MHz to 45 MHz	-71	-72	
45 MHz to 500 MHz	-97	-98	
500 MHz to 2 GHz	-120	-121	
2 GHz to 10 GHz	-118	-121	
10 GHz to 24 GHz	-116	-121	
24 GHz to 30 GHz	-107	-112	
30 GHz to 40 GHz	-102	-108	

Table 4-1 Typical System Specifications (Continued)

40 GHz to 45 GHz	-99	-106		
45 GHz to 50 GHz	-97	-104		
50 GHz to 60 GHz	-97	-104		
60 GHz to 67 GHz	-92	-103		
67 GHz to 70 GHz	-77			-84
70 GHz to 75 GHz	-81			-87
75 GHz to 80 GHz	-91			-97
80 GHz to 100 GHz	-94			-100
100 GHz to 110 GHz	-95			-100
System Dynamic Range (dB)	1.0 mm Test Port	1.85 mm PNA Port	Waveguide Port	
10 MHz to 45 MHz	+63	+65		
45 MHz to 500 MHz	+94	+97		
500 MHz to 2 GHz	+120	+123		
2 GHz to 10 GHz	+116	+123		
10 GHz to 24 GHz	+111	+121		
24 GHz to 30 GHz	+100	+112		
30 GHz to 40 GHz	+92	+107		
40 GHz to 45 GHz	+84	+101		
45 GHz to 50 GHz	+85	+103		
50 GHz to 60 GHz	+80	+100		
60 GHz to 67 GHz	+75	+95		
67 GHz to 70 GHz	+68			+82
70 GHz to 75 GHz	+74			+87
75 GHz to 80 GHz	+85			+98
80 GHz to 100 GHz	+89			+101
100 GHz to 110 GHz	+87		+98	
Test Port Damage Level (dBm)	1.0 mm Test Port	1.85 mm PNA Port	Waveguide Port	
10 MHz to 110 GHz	+27	+27	+27	

- a. Assumes a 30 inch cable from the PNA 1.85 mm Test Port Out is used to provide the 10 MHz to 67 GHz source signal. The standard configuration does not have a bias-tee in the 1.0 mm test head and uses this connection.
- b. Assumes a 30 inch cable from the PNA Source Out bulkhead connector is used to provide the 10 MHz to 67 GHz source signal. The Option 017 and 018 configurations includes a bias-tee in the 1.0 mm test head and use this connection.

N5227A Rear Panel Specifications

Table 4-2 N5227A Rear Panel IF Inputs

IF Connector Input Frequency	8.333 MHz
0.1 dB Compression Points at IF inputs	-27.0 dBm
Nominal Input Impedance at IF Inputs	50 Ohms
RF Damage Level to IF Connector Inputs	-20.0 dBm
DC Damage Level to IF Connector Inputs	25 Volts

Table 4-3 N5227A RF and LO Outputs

Rear Panel LO Power - Test Port Frequencies Above 67 GHz	
67 GHz to 110 GHz ^a	-7 to -13 dBm
Rear Panel RF Power - Test Port Frequencies Above 67 GHz	
67 GHz to 76 GHz ^b	-4 to -10 dBm
76 GHz to 96 GHz ^b	+1 to -5 dBm
96 GHz to 110 GHz ^b	+5 to -1 dBm

- a. For rear panel LO port frequency, divide by 8.
- b. For rear panel RF port frequency, divide by 6.

N5251A Test Head Bias-Tees Specifications

Table 4-4 Test Head Bias Input Connector

GNDU:	Sub Mini-Triaial Connector, Trompeter BJ152 Insulated Bulkhead Jack (150 Series)
SENSE:	Sub Mini-Triaial Connector, Trompeter BJ152 Insulated Bulkhead Jack (150 Series)
FORCE:	Sub Mini-Triaial Connector, Trompeter BJ152 Insulated Bulkhead Jack (150 Series)
Maximum Voltage:	± 30 VDC (typical)
Damage Voltage:	± 40 VDC
Maximum Current:	± 0.5 AMP

Figure 4-1 Internal Connection Diagram for the Test Head Bias-Tee

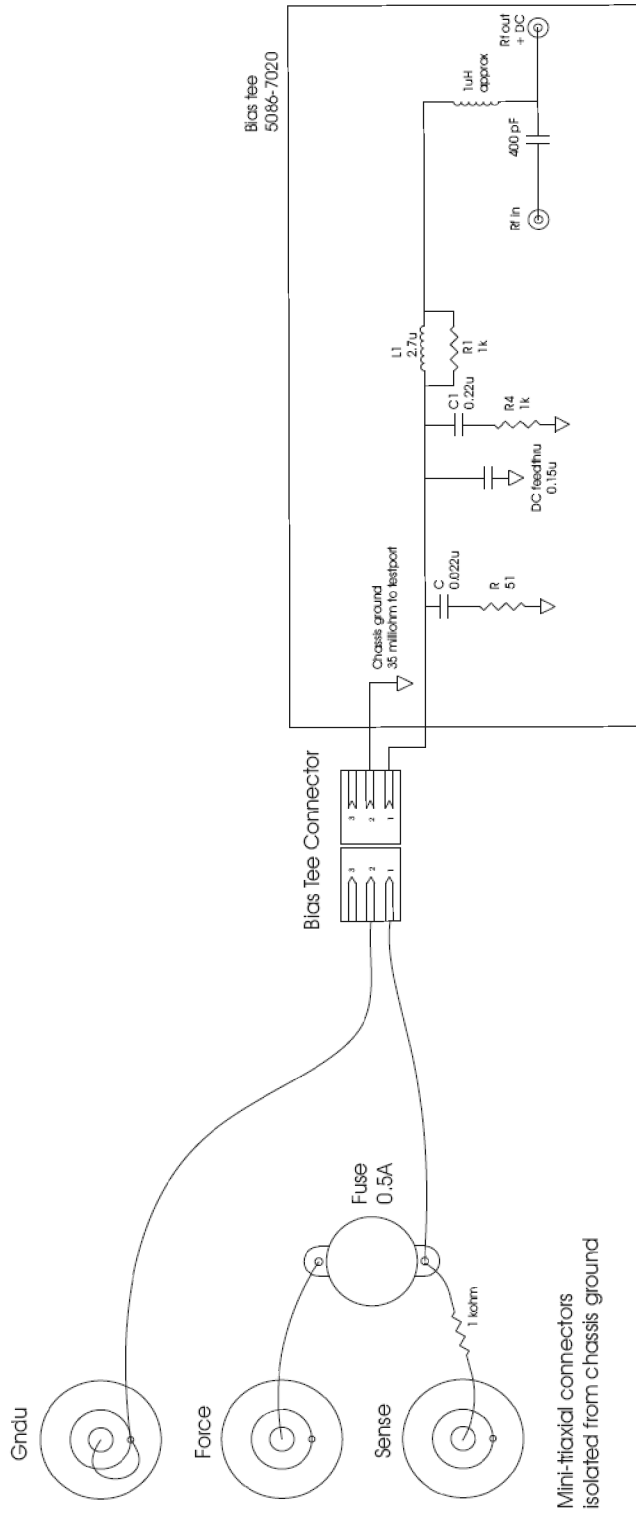

TEST HEAD BIAS-TEE CIRCUIT
 Agilent Restricted

N5251_001_401

Figure 4-2 External Connection Diagram for the Test Head Bias-Tee

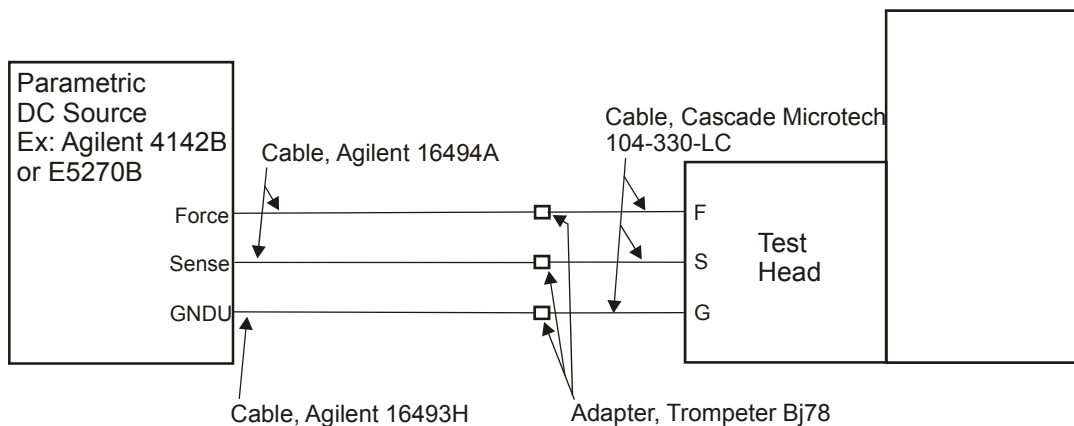

NOTE: GNDU is connected to only one of the test heads.
A second GNDU connection is not required.

N5250_001_402

NOTE Refer to the documentation of your parametric DC source for the appropriate cables to use for connecting to the test head bias tee.

- Test head sub-miniature triax connectors are BJ152 bulkhead jacks from Trompeter Electronics (www.trompeter.com).
- Parametric DC source connectors are standard triax.

Test Head Module Dimensions

Test head module dimensions are shown in [Figure 4-3. on page 4-7.](#)

Figure 4-3. Test Head Module Dimensions for Mounting
 Left Test Head, Top View

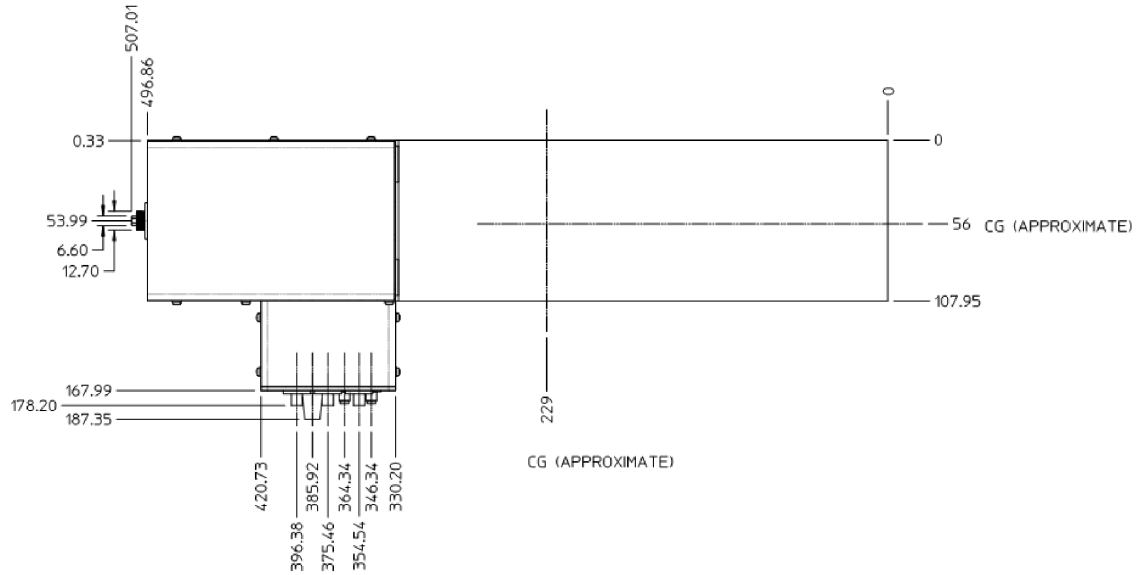

Left Test Head, Front View

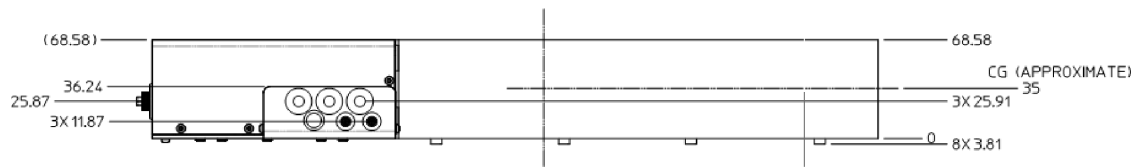

Left Test Head, Bottom View

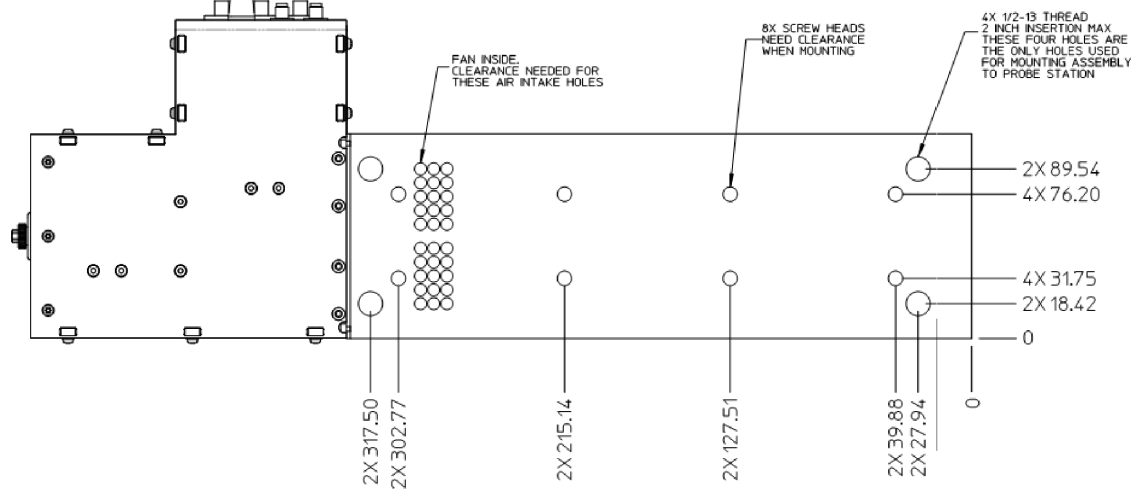

Left and Right Heads are Symmetrical
 All dimension are in mm

N5250_001_313

5 Maintenance and Support

Maintenance

WARNING To prevent electrical shock, disconnect the analyzer from the mains source before cleaning. Use a dry cloth or one slightly dampened with water to clean the external case parts. Do not attempt to clean internally.

Physical Maintenance

Clean the cabinet, including the front panel, using a dry or slightly damp cloth only.

Electrical Maintenance

Refer to [“Keysight Support, Services, and Assistance”](#) on page 5-4.

Caring for Waveguide (WG) Interfaces

A clean surface at millimeter-wave frequencies is much more important than at lower frequencies because any debris on the waveguide surface can potentially distort the measurement results.

Caring for WG interfaces is not difficult. Dirt and dust can be removed using the following:

- Isopropyl alcohol 99.5%¹
- Lint-free cloth
- Pressurized air (for dust removal)

To remove dirt on the waveguide surface, simply put a few drops of isopropyl alcohol on a lint-free cloth and gently wipe the surface.

To remove dust, simply spray the pressurized air on the waveguide surface.

1. Use isopropyl alcohol only in a well-ventilated area. Allow all residual alcohol moisture to evaporate, and the fumes to dissipate, prior to assembling waveguide interfaces.

Principles of Connector Care

Proper connector care and connection techniques are critical for accurate and repeatable measurements. Refer to [Table 5-1](#) for tips on connector care.

Prior to making connections to your analyzer, carefully review the information about inspecting, cleaning, and gaging connectors. Refer to the calibration kit documentation for detailed connector care information.

For course numbers about additional connector care instruction, contact Keysight Technologies. Refer to [“Contacting Keysight” on page 5-4](#).

Table 5-1 Connector Care Quick Reference Guide

Handling and Storage	
Do <ul style="list-style-type: none"> • Keep connectors clean • Extend sleeve or connector nut • Use plastic end-caps during storage 	Do Not <ul style="list-style-type: none"> • Touch mating-plane surfaces • Set connectors contact-end down • Store connectors or adapters loose
Visual Inspection	
Do <ul style="list-style-type: none"> • Inspect all connectors carefully • Look for metal particles, scratches, and dents 	Do Not <ul style="list-style-type: none"> • Use a damaged connector - ever
Connector Cleaning	
Do <ul style="list-style-type: none"> • Try compressed air first • Use isopropyl alcohol^a • Clean connector threads 	Do Not <ul style="list-style-type: none"> • Use any abrasives • Get liquid into plastic support beads
Gaging Connectors	
Do <ul style="list-style-type: none"> • Clean and zero the gage before use • Use the correct gage type • Use correct end of calibration block • Gage all connectors before first use 	Do Not <ul style="list-style-type: none"> • Use an out-of-specification connector
Making Connections	
Do <ul style="list-style-type: none"> • Align connectors carefully • Make preliminary connection contact lightly • Turn only the connector nut • Use a torque wrench for final connection 	Do Not <ul style="list-style-type: none"> • Apply bending force to connection • Over tighten preliminary connection • Twist or screw any connection • Tighten past torque wrench “break” point

- a. Cleaning connectors with alcohol shall only be done with the instrument’s power cord removed, and in a well-ventilated area. Allow all residual alcohol moisture to evaporate, and the fumes to dissipate, prior to energizing the instrument.

Keysight Support, Services, and Assistance

Information on the following topics is included in this section.

- “Service and Support Options”
- “Contacting Keysight”
- “Shipping an Item to Keysight for Service or Repair”

Service and Support Options

The N5251A system has a *three-year on-site service warranty* which covers troubleshooting the system to an individual instrument, device, or cable. The service warranty includes repair or replacement of defective components. Most repairs require that the defective component be returned to Keysight.

NOTE Extended warranties are available in many geographical areas. Contact Keysight for additional information on available service agreements for this product. Refer to “Contacting Keysight” on page 5-4.

Contacting Keysight

Assistance with test and measurements needs and information or finding a local Keysight office are available on the Web at:

<http://www.keysight.com/find/assist>

If you do not have access to the Internet, please contact your Keysight field engineer.

NOTE In any correspondence or telephone conversation, refer to the Keysight product by its model number and full serial number. With this information, the Keysight representative can determine whether your product is still within its warranty period.

Shipping an Item to Keysight for Service or Repair

IMPORTANT Keysight Technologies reserves the right to reformat or replace the internal hard disk drive in the network analyzer, contained in this system, as part of its repair. This will erase all user information stored on the hard disk. It is imperative, therefore, that you make a backup copy of your critical test data located on the analyzer’s hard disk before shipping it to Keysight for repair.

If you wish to send an item from your system to Keysight Technologies for service or repair:

- Contact Keysight to open a service order. Refer to “Contacting Keysight” on page 5-4.
- Include a complete description of the service requested or of the failure and a description of any failed test and any error message.
- Ship the item using the original or comparable antistatic packaging materials.

6 Performance Tests and Checks

System Preparation and Analyzer Warm Up

NOTE To achieve the maximum system stability, allow the analyzer to warm up for at least 90 minutes.

Complete the procedures in [Chapter 3, "System Installation,"](#) to assemble and configure the system. After you press the Preset button, the PNA should display a frequency range of 10 MHz to 110 GHz.

Torquing Connections

All connections made during the System Check and System Performance Verification procedures should be carefully torqued using the tools provided in the 85059A kit.

Long Term Storage of Test Results

It is recommended that you store results from the System Check and the System Performance Verification procedures for future reference. Prior results can be useful when evaluating changes in system performance. After completing a successful test process that accurately represents the system performance, store the test result files in the directory D:\sysver results. It may be necessary to create this directory if it does not already exist. Create a new subdirectory when a new set of test results is stored. Use the current date as the name for the subdirectory. Example: D:\sysver results\2012 April 15\.

Protect Against Electrostatic Discharge (ESD)

This is important. If not properly protected against, electrostatic discharge can seriously damage your analyzer, resulting in costly repair.

CAUTION To reduce the chance of electrostatic discharge, follow all of the recommendations outlined in ["Electrostatic Discharge Protection" on page 1-4,](#) for all of the procedures in this chapter.

Review the Principles of Connector Care

Proper connector care and connection techniques are critical for accurate and repeatable measurements. Refer to [Table 5-1 on page 5-3](#) for tips on connector care.

Prior to making connections to your analyzer, carefully review the information about inspecting, cleaning, and gaging connectors. Refer to the calibration kit documentation for detailed connector care information.

System Check

1. Connect a 1.0 mm short to each port. Adapters may be used as needed.
2. Restart the PNA application and perform a factory preset by pressing the **PRESET** key.
3. Set the IF bandwidth to 1 kHz by pressing **Response > Avg > IF Bandwidth**.
4. Display the receiver traces as shown in **Figure 6-1** and **Figure 6-3** by pressing **Utility > System > Service > Utilities > Receiver Display**.

The traces on the display should be similar to the example traces shown in **Figure 6-1** and **Figure 6-2**. If there are power holes or other unexpected characteristics, examine the system for loose or damaged cables, dirty or damaged connectors, proper connector torque, etc.

Figure 6-1 Typical Receiver Display for a 2-Port System

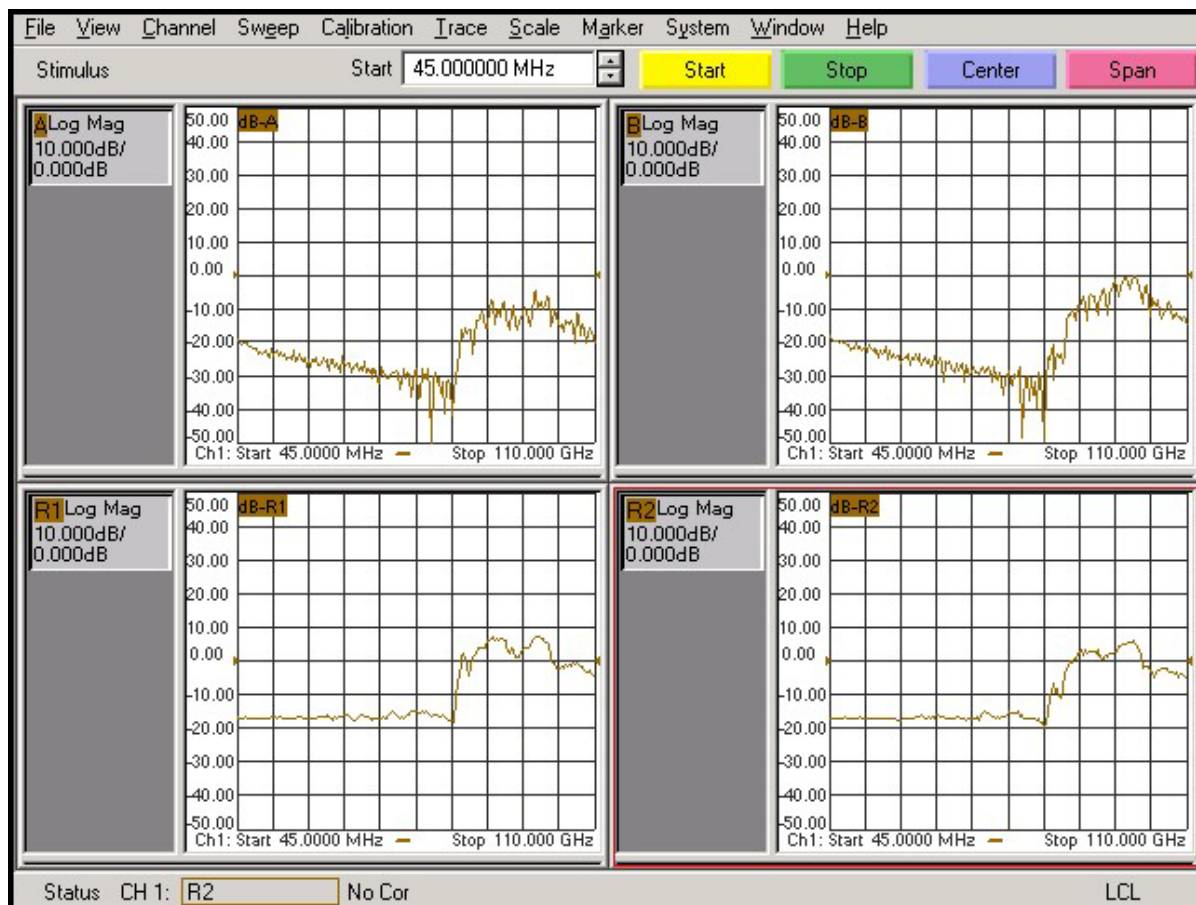
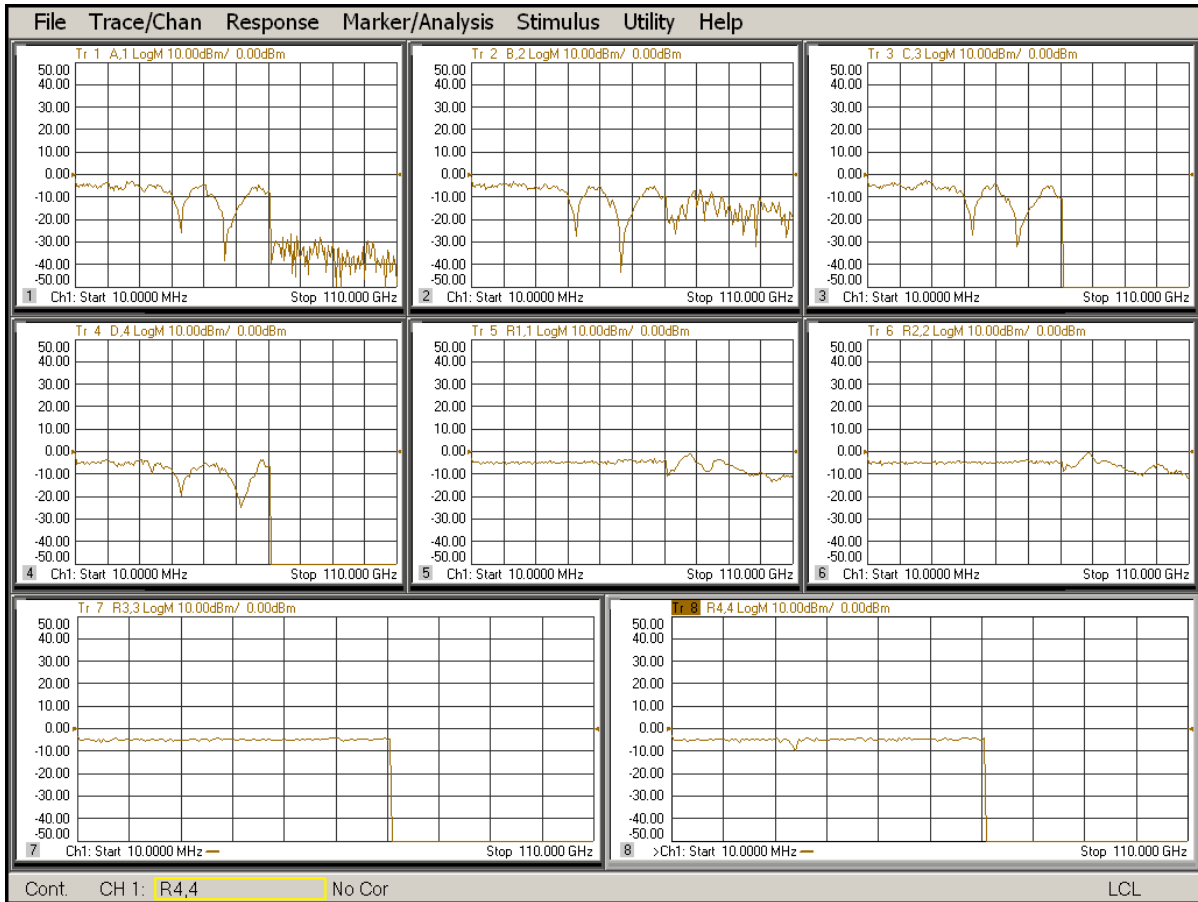

Figure 6-2 Typical Receiver Display for a 4-Port System



When you have a display that represents the current system performance, capture the display in a file and save the file in the directory D:\sysver\results (create this directory if it does not already exist). To capture the display in a file, select: **File > Print > Print to File**.
An example of a recommended file name is "opcheck_May_15_2012.png". (These instructions assume you have previously created a subdirectory for the current date.)

System Performance Verification

NOTE Since the N5251A has typical (non-warranted) specifications only, the SYSTEM PERFORMANCE VERIFICATION is not a PASS/FAIL test. The SYSTEM PERFORMANCE VERIFICATION is a procedure to establish current performance of the system. See [“Interpreting the Verification Results” on page 6-15](#) for more detail.

System verification is performed at the N5251A system 1.0 mm port connectors over a frequency range of 45 MHz to 110 GHz with an Keysight 85059A 1.0 mm Calibration and Verification kit. The basic verification process checks a pair of ports at one time. Verification of a 2-port system typically takes about 30 minutes. Verification of a 4-port system typically takes about 45 minutes.

The system verification procedure is automated by the analyzer firmware. For each verification device, the system measures the magnitude and phase for all four S-parameters and reads data for the device from the 85059A kit. The procedure displays the measured data along with the kit data to allow a visual comparison.

During the system verification process, it is NECESSARY that the verification devices be measured with their female connectors connected to Port 1 and their male connectors connected to Port 2. A 1.0 mm female-to-female cable connected to Port 2. This cable is included in the 85059A 1.0 mm Calibration and Verification kit.

When to Verify

After installation of the system is complete, a performance verification is necessary to assure proper system operation. This initial verification is included with the installation.

After the initial verification, the verification should be repeated once a year. This recommended interval assumes that Keysight cables are used with the system.

If non-Keysight cables, adaptors, or other fixtures are used, the verification schedule must be determined by the user, as the characteristics of these devices are unknown. In establishing a verification schedule, the following factors should be considered:

- Frequency of use
- Amount of cable movement
- Amount of drift occurring between prior verifications

NOTE Performance verification of a system performed at long intervals is *not* to be confused with measurement calibration. Measurement calibration typically is performed on a daily basis, or when the measurement setup or conditions have changed.

Materials Required

The following materials are required to run the tests:

- N5251A system (including system cables)
- 85059A 1.0 mm Calibration and Verification kit
- System Verification program, revision A.05.08 or later. To check the program revision, open the System Verification utility (step 2 in “[Verification Procedure](#)” on page 6-8), then click the Help tab. The System Verification utility is an independent program installed on the PNA. Instructions for updating the System Verification utility are located at http://na.support.keysight.com/pna/pna_testing.html.

General Preparation

Prepare for performance verification by completing the following procedure:

1. Measure the environment temperature. The temperature must be between +20 °C and +26 °C. Additionally, the temperature cannot vary by more than ± 1 °C after calibration.
2. Apply power to the system components in the following order:
 - a. N5261/2A millimeter head controller
 - b. N5227A PNA
3. Remember to allow at least 90 minutes for warm up and temperature stabilization of the components. The temperature of the standards in the 85059A 1.0 mm Calibration and Verification kit must also be stable at the system ambient temperature.

Verification Procedure

1. Insert the USB memory stick from the 85059A kit into the PNA.
2. Press **Utility > System > Service > System Verification**. The **System Verification** dialog box is displayed; refer to [Figure 6-3](#).

Figure 6-3 System Verification Dialog Box

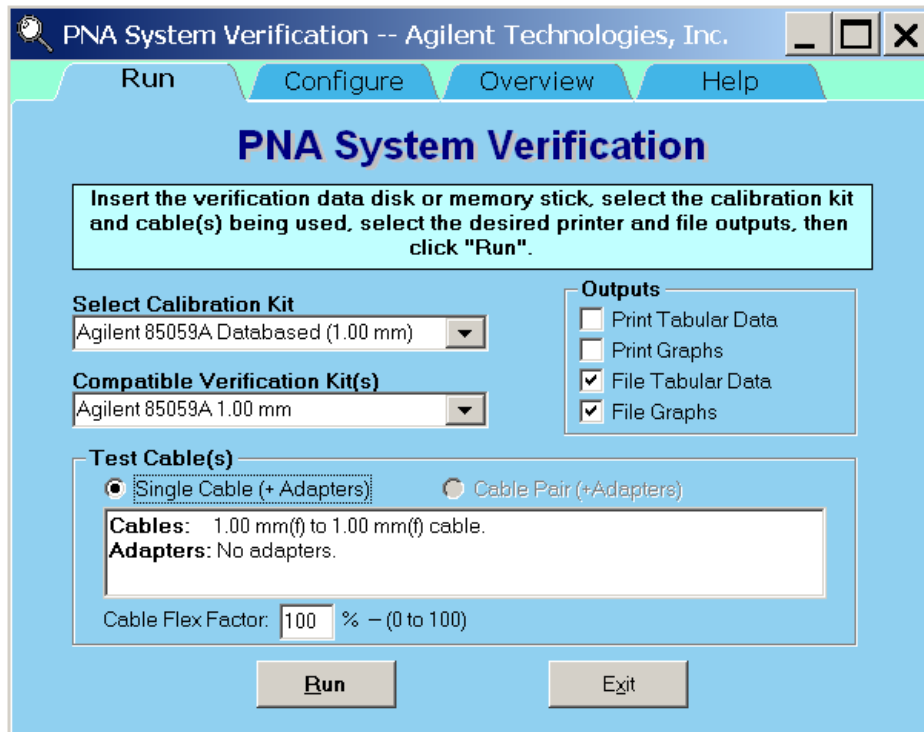

3. In the **Select Calibration Kit** drop-down menu, select the “Keysight 85059A Data-based (1.00 mm)” calibration kit by clicking on it. The corresponding verification kit to use is automatically selected. Refer to [Figure 6-3](#).
4. Under **Test Cable(s)**:
 - Select **Single Cable (+ Adapters)**
 - Set **Cable Flex Factor** to 100%
5. Under **Outputs**, the recommended selections are “**File Tabular Data**” and “**File Graphs**.” Other selections may be made. For additional information, click on the **Help** tab, then click **Detailed Help**. This will take you into the PNA Help system. Scroll down to Step 5, “Under **Printer Output...**”.
6. Select the **Configure** tab. The window shown in [Figure 6-4 on page 6-9](#) is displayed.
7. Under **Measure Ports**, select the checkbox for the desired pair of ports. (The verification process is performed on pairs of ports.)
8. Under **Measure Devices**, select both checkboxes.

Figure 6-4 System Verification Configure Tab

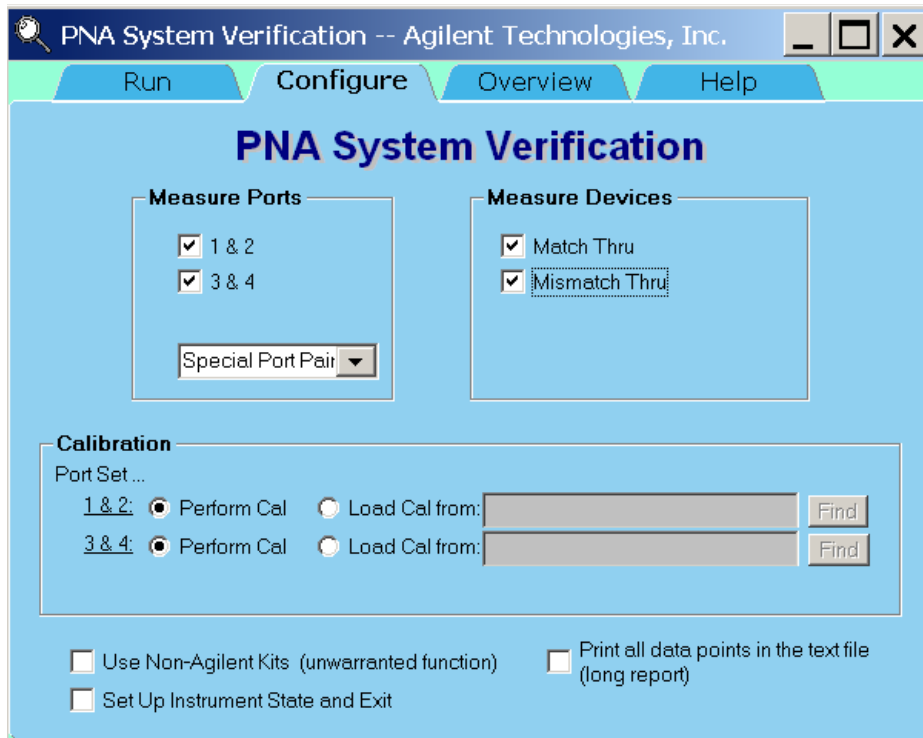

9. Select the **Run** tab to return to the previous window.

NOTE The remaining instructions assume Port 1 and Port 2 are being verified. Modify the instructions appropriately for Port 3 and Port 4.

10. Click **Run**.

11. Enter the serial number for the 85059A kit. The other numbers are optional.

12. Click **Continue**.

13. As prompted, install the 1.0 mm female to female cable (8.8 cm, Keysight part number 11500-60001) onto the right test head (Port 2). See [Figure 6-5 on page 6-10](#). This cable is part of the 85059A 1.0 mm Calibration and Verification kit and is considered to be a test port cable.

Figure 6-5 Test Port Cable for System Verification

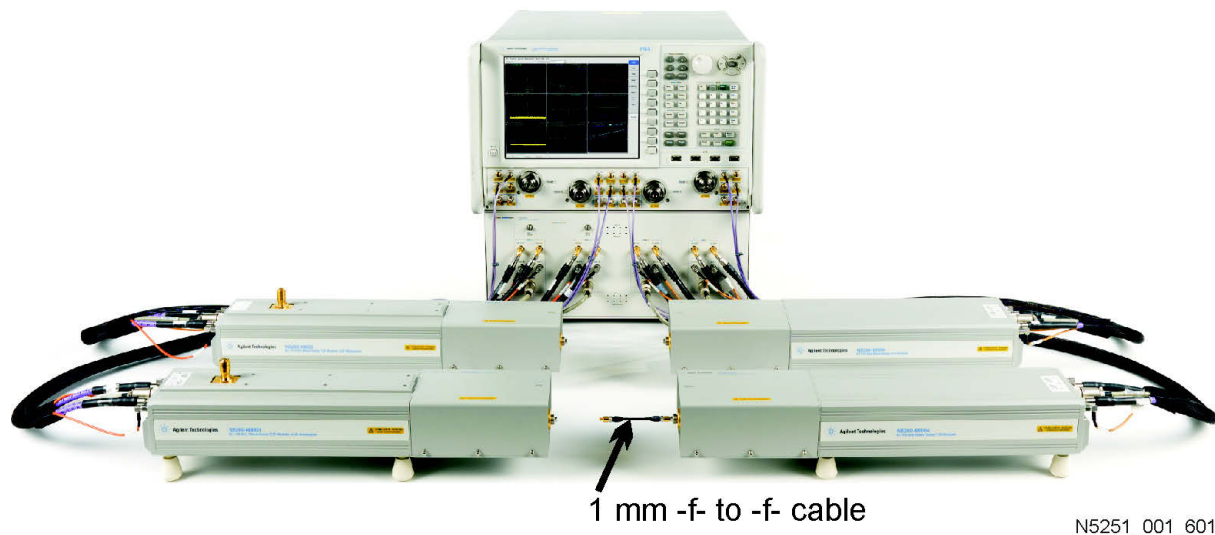

CAUTION Do not remove this test port cable once the Calibration/Verification process has begun. If the test port cable becomes loose or is removed during the calibration/verification process, the calibration is invalid.

CAUTION Do not pull on the connectors on the ends of the test port cable—this will damage the cable. Avoid damaging the cable once it is connected to Port 2 when making the thru connection between the two test heads. This is best done by placing the two test heads on a smooth surface and gently sliding the right test head (Port 2) towards the left test head (Port 1).

14. Follow the prompts on the analyzer for performing a full 2-port calibration. The parameters for the calibration are set up automatically by the program. When connecting calibration standards to the end of the test port cable, be sure to use a backup wrench to prevent twisting the cable.

15. At the last step of the calibration sequence it is necessary to make a direct connection from Port 1 to Port 2. To make the thru connection:

- Gently slide the right test head (Port 2) towards the left test head (Port 1) until the end of the cable is at Port 1.
- Gently slide the heads together a little bit at a time, while turning the threaded ring on Port 1 by hand onto the end of the cable. Do not use the threaded ring on the test port connector to pull the cable into the connector.
- Repeat this process until the cable is firmly seated into Port 1, then *lightly* tighten the threaded ring.
- Use a torque wrench on the Port 1 threaded ring and a backup wrench on the cable to tighten the connection.

16. When the calibration process is completed, you will be prompted to save the calibration state to a file. Saving the calibrated state is recommended. The saved calibration may be useful if it becomes

necessary to remeasure the verification devices. Provide a name for the file that will allow you to reuse the calibration as needed.

17. After completion of the full 2-port calibration, follow the prompts on the analyzer for measuring the verification devices. Use the match thru and mismatch thru verification standards provided with the 85059A 1.0 mm Calibration and Verification kit. Connect the devices between the test port cable and Port 1. The Match Thru and the Mismatch Thru are very similar in appearance. The Mismatch Thru has a groove machined around its circumference.

NOTE It is recommended to connect the Verification Standards to the test port cable on Port 2 prior to attempting to connect to Port 1. Then follow the recommended procedure for making a thru connection outlined under [Step 15 on page 6-10](#) to avoid damaging the cable.

18. When the verification process has been completed for ports 1 and 2, you are prompted with the directory location of the result files. Make a note of this directory for later reference.
19. If ports 3 and 4 were selected under the **Configure** tab earlier, you will be prompted to repeat the process for those ports.
20. When you have completed the system verification process for all ports, and you have results that represent current system performance, save the result files as described in [“Saving Verification Results” on page 6-16](#).

Verification Results Files

When System Verification is configured as recommended, the process produces five files for each port pair - one text file and four.png files. The text file contains model numbers and serial numbers of the PNA and 85059A kit, along with tabular lists of all results. The other files are screen captures of the magnitude and phase traces for each verification device. All file names contain the date and time of the system verification.

Refer to the example screen captures in [Figure 6-6](#), [Figure 6-7](#), [Figure 6-8](#), and [Figure 6-9](#). The windows are labeled 1, 2, 3, and 4. Window 1 is S_{11} , window 2 is S_{21} , window 3 is S_{12} , and trace 4 is S_{22} . Two traces are shown for each measurement - a black trace and a colored trace. The black traces represent the factory measured data for the verification devices. The colored traces represent the actual measured data from the calibrated system.

Figure 6-6 Magnitude for Matched Thru

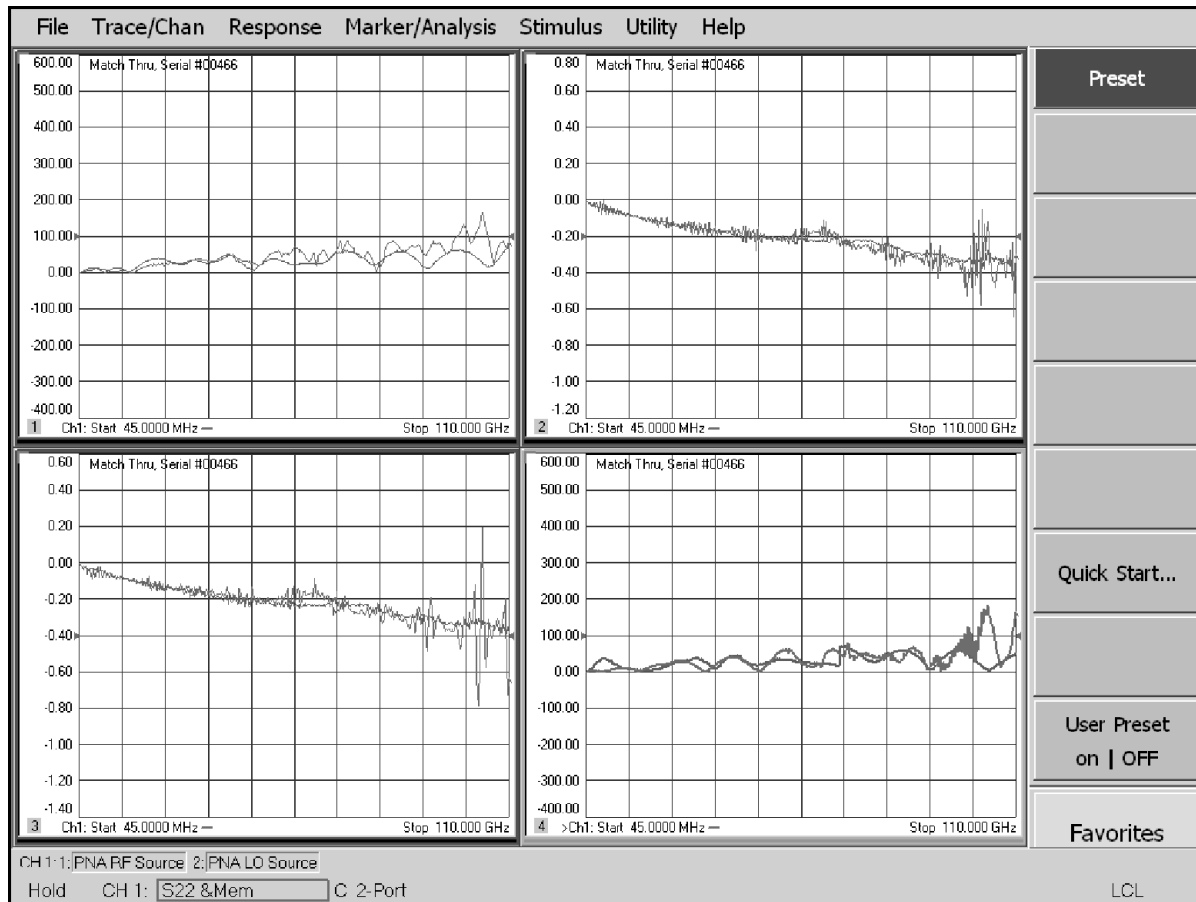

n5250_001_605

S_{11} and S_{22} are linear magnitude with a scale of milliunits. S_{21} and S_{12} are dB.

Figure 6-7 Phase for Matched Thru

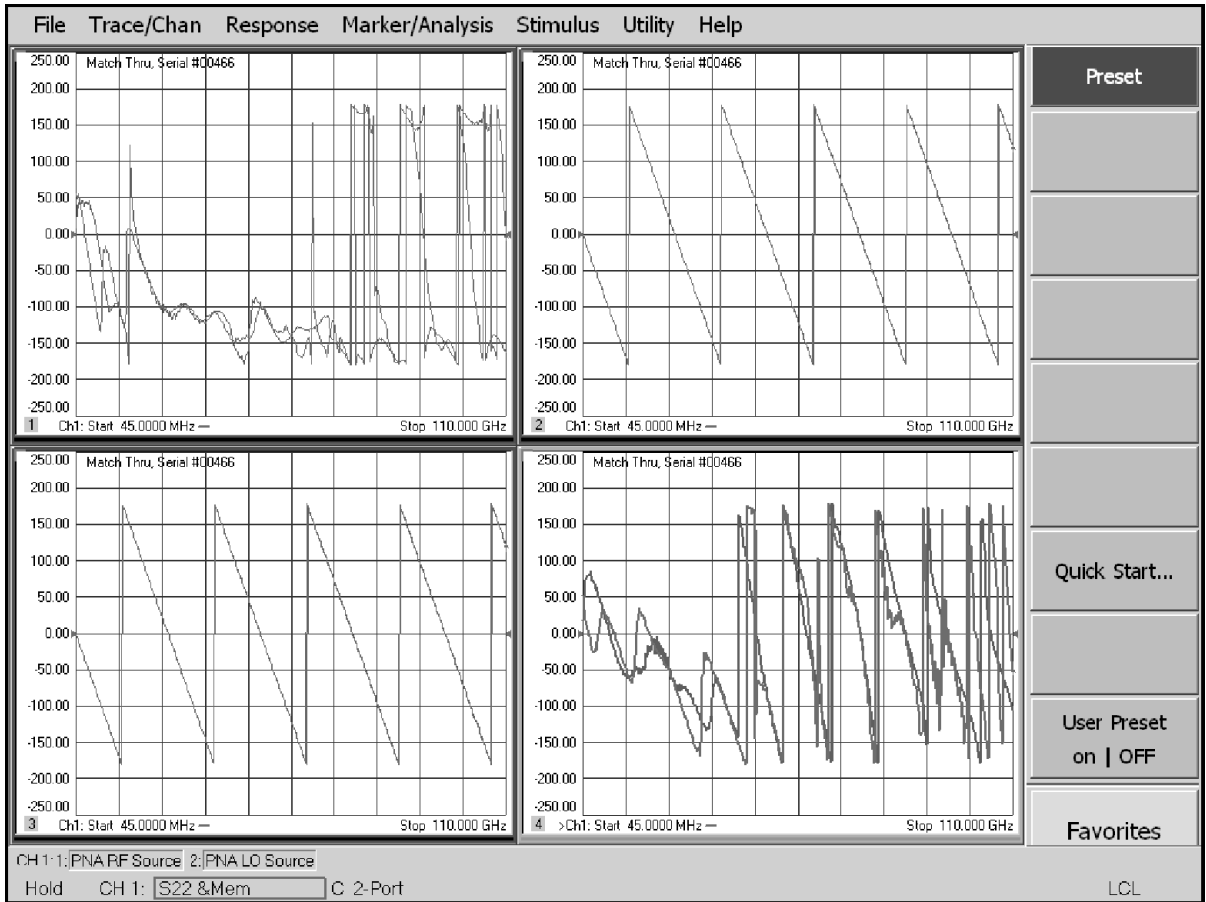

n5250_001_606

Figure 6-8 Magnitude for Mismatched Thru

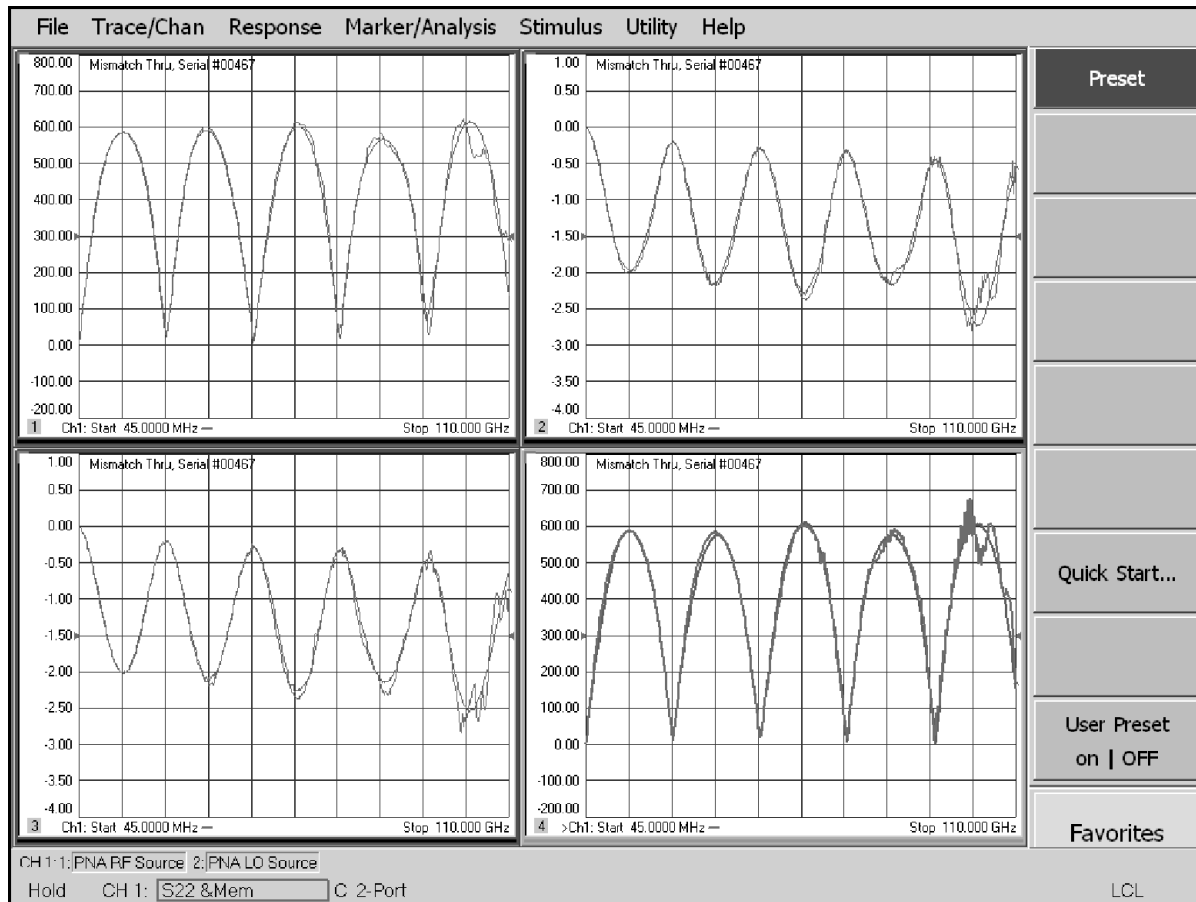

n5250_001_607

S_{11} and S_{22} are linear magnitude with a scale of milliunits. S_{21} and S_{12} are dB.

Figure 6-9 Phase for Mismatched Thru

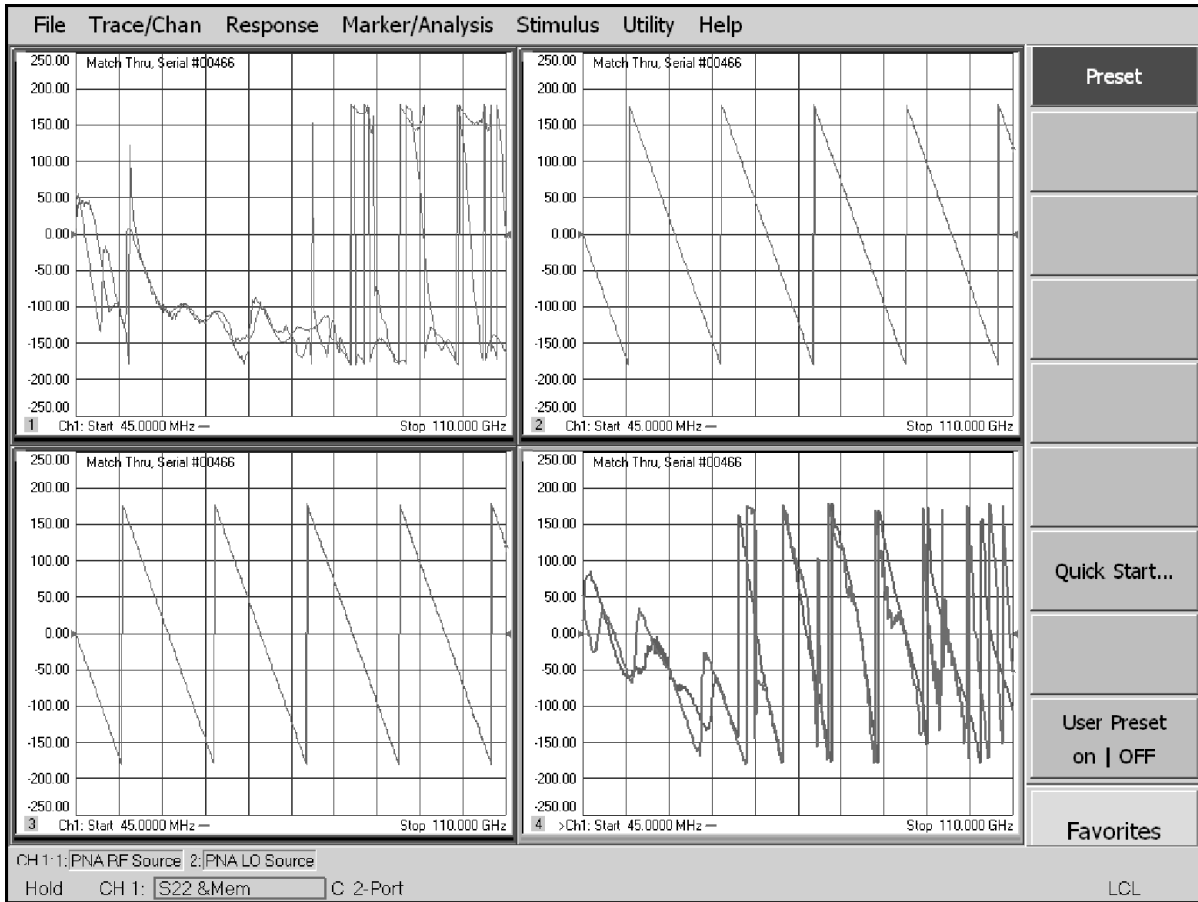

n5250_001_608

Interpreting the Verification Results

The purpose of the N5251A system verification process is to demonstrate that the system is making reasonable measurements. There are no hard specifications on the N5251A system, so there are no pass/fail limits from the system verification measurements. The results allow the user to compare the actual measured data to the factory measured data for each verification device.

The example traces on the previous pages show typical differences between measured and factory data. Ignore phase differences for S_{11} , S_{22} , S_{33} , and S_{44} when comparing measured data to factory data.

Improving the Verification Results

IMPORTANT Inspect all connections. *Do not* remove the test port cable from the analyzer test port. This *will invalidate* the calibration that you performed earlier.

1. Disconnect and clean the device that failed the verification measurement.
2. Reconnect the device making sure that all connections are carefully torqued.
3. Measure the device again using the previous calibration.
4. If the device still fails the verification measurement, repeat the full system verification process including calibration.

Saving Verification Results

When you have system verification results that represent current system performance, save the results files (five files for each port pair) in the appropriate subdirectory under D:\sysver results.

7 Replaceable Parts

Ordering Information

To order a part listed in the replaceable parts lists:

- include the part number
- indicate the quantity required
- Contact Keysight Technologies for instructions on where to send the order. Refer to [“Contacting Keysight” on page 5-4.](#)

To order a part that is not listed in the replaceable parts lists:

- include the instrument model number and complete instrument serial number
- include the description and function of the part
- indicate the quantity required
- Contact Keysight Technologies for instructions on where to send the order. Refer to [“Contacting Keysight” on page 5-4.](#)

Replaceable Parts

Table 7-1 Replaceable Parts List

Keysight Part Number	Description
Test Head Module Parts:	
2110-0046	Fuse (inch) 0.5A, 125V NTD BI. Fuse for bias tee (option 017 and 018)
System Front Cables:	
8121-1221	RF and LO 3.5 mm cable (48" length)
85105-60033	IF signal cable (SMA) (48" length)
85105-60030	Controller bias cable (48" length)
8121-1233	N5227A PNA front panel access port RF 1.85 mm (m)-(m) cable (30" length)
1250-2604	SMA right angle adapter (Used only with 8121-1221 cable.)
System Rear Cables:	
8120-6818	Test set interface cable
5061-9038	RF cables

-
- A**
- analyzer**
 - warmup time, 6-2
- B**
- battery disposal**, 1-7
 - before applying power**, 1-2
- C**
- cabling**
 - front panel, 3-11
 - millimeter-wave test head, 3-13
 - rear panel, 3-9
 - care of connectors**, 3-7, 5-3, 6-3
 - care of waveguide**, 5-2
 - CE mark**, 1-6
 - certification**, 1-ii
 - check**
 - system, 6-4
 - cleaning**
 - connectors, 5-3
 - waveguide, 5-2
 - coaxial**
 - measurement, 2-4
 - configuration**
 - coaxial, 2-2
 - wafer probe, 2-2
 - configuring PNA software**, 3-15
 - connectors**
 - care of, 3-7, 5-3, 6-3
 - care quick reference, 5-3
 - cleaning, 5-3
 - contacting Keysight**, 5-4
 - contents**
 - checklist, 3-3
 - of shipment, 3-3
 - CSA mark**, 1-6
 - customer engineering**
 - Keysight, 3-2
- D**
- device connections**
 - system verification, 6-10
 - DFARS**, 1-ii
 - dimensions**
 - system, 3-7
 - system components, 3-7
 - test head module, 4-6
 - documentation**
 - on the Web, 1-iii
 - printing from the Web, 1-iii
- E**
- earth ground**, 1-2
 - electrostatic discharge**, *See ESD*
- environmental requirements**
system, 3-6
- ESD**
protection, 1-4, 3-7, 6-2
- F**
- front panel cabling**, 3-11
- G**
- general preparation required for system verification**, 6-7
 - general safety considerations**, 1-2
 - ground, safety earth**, 1-2
- H**
- head controller**, 2-6
- I**
- improving verification results for system verification**, 6-16
 - installing**
 - the system, 3-2
 - instruction documentation symbol**, 1-6
 - instrument markings**, 1-6
 - interpreting verification results for system verification**, 6-15
 - ISM1-A mark**, 1-6
- K**
- Keysight**
 - assistance, 5-4
 - contacting, 5-4
 - customer engineering, 3-2
 - service and support options, 5-4
 - services, 5-4
 - support, 5-4
 - system installation, 3-2
- L**
- lithium battery disposal**, 1-7
 - lock link kit**, 3-9
- M**
- maintenance**
 - cleaning, 5-2
 - electrical, 5-2
 - physical, 5-2
 - system, 5-2
 - materials required for system verification**, 6-7
 - measurement**
 - coaxial, 2-4
 - wafer probe, 2-5
- millimeter head controller**, 2-6
- millimeter-wave test head module**
cable connections, 3-13
- millimeter-wave test head modules**
description of, 2-7
theory of operation, 2-8
- mount PNA on top of controller**, 3-9
- N**
- N5251A system**
 - as shipped, 3-2
 - basic configurations, 2-4
 - check, 6-4
 - components
 - weights and dimensions, 3-7
 - description of, 2-2
 - environmental requirements, 3-6
 - front panel cabling, 3-11
 - illustration of, 2-2
 - installation, 3-2
 - maintenance, 5-2
 - power requirements, 3-5
 - rear panel cabling, 3-9
 - receiving, 3-2
 - replaceable parts, 7-3
 - shipment checklist, 3-3
 - shipment contents, 3-3
 - shipment for service or repair, 5-4
 - site preparation, 3-5
 - space requirements, 3-7
 - specifications, 4-2
 - verification, 6-6
 - weight and dimensions, 3-7
 - N5261A millimeter head controller**, 2-6
 - N5262A millimeter head controller**, 2-6
 - nformation**, 1-1
- O**
- operation**
 - millimeter head controller, 2-6
 - millimeter-wave test head modules, 2-8
 - options**
 - service and support, 5-4
 - system, 2-3
 - ordering information**
 - replaceable parts, 7-2
- P**
- parts**
 - replaceable
 - ordering information, 7-2
 - PNA software, configuring**, 3-15
 - power requirements**
 - system, 3-5
 - printing**
-

documentation, 1-iii
product
certification, 1-ii
warranty of document, 1-ii
protection
against ESD, 1-4, 3-7, 6-2

R

rear panel
specifications, 4-4
rear panel cabling, 3-9
receiver display utility, 6-4
receiving
the system, 3-2
regulatory information, 1-5
repair
shipping to Keysight for, 5-4
replaceable parts
ordering information, 7-2
system, 7-3
Restricted Rights Notice, 1-ii

S

safety
considerations, 1-2
earth ground, 1-2
symbols
caution
warning, 1-2
saving verification results for system verification, 6-16
service
contacting Keysight, 5-4
options, 5-4
shipping to Keysight for, 5-4
warnings, 1-2
warranty
standard, 5-4
shipment
checklist, 3-3
contents, 3-3
for service or repair, 5-4
site preparation
system, 3-5
software, PNA, configuring, 3-15
space requirements
system, 3-7
specifications
rear panel, 4-4
stabilization, warm up time, 6-2
system, 4-2
test head bias tees, 4-4
stabilization
warm up time, 6-2
support
contacting Keysight, 5-4
options, 5-4

organization, 5-4
system
as shipped, 3-2
basic configurations, 2-4
check, 6-4
components
weight and dimensions, 3-7
description of, 2-2
environmental requirements, 3-6
front panel cabling, 3-11
illustration of, 2-2
installation, 3-2
maintenance, 5-2
millimeter-wave test head cabling, 3-13
mount PNA on top of controller, 3-9
options, 2-3
power requirements, 3-5
rear panel cabling, 3-9
receiving, 3-2
replaceable parts, 7-3
shipment checklist, 3-3
shipment contents, 3-3
shipment for service or repair, 5-4
site preparation, 3-5
space requirements, 3-7
specifications, 4-2
verification, 6-6
device connections, 6-10
dialog box, 6-8, 6-9
general preparation, 6-7
improving verification results, 6-16
interpreting verification results, 6-15
materials required, 6-7
saving verification results, 6-16
verification results files, 6-11
weight and dimensions, 3-7

T

test head bias tees
specifications, 4-4
test head module
cable connections, 3-13
dimensions, 4-6
test head modules
description of, 2-7
test heads
description of, 2-7

V

verification
system, 6-6
device connections, 6-10
dialog box, 6-8, 6-9
general preparation, 6-7
improving verification results, 6-16

interpreting verification results, 6-15
materials required, 6-7
saving verification results, 6-16
verification results files, 6-11
verification results files for system verification, 6-11

W

wafer probe
equipment and accessories, 2-5
measurement, 2-5
warm up
analyzer, 6-2
warnings for servicing, 1-2
warranty
service
standard, 5-4
warranty of document, 1-ii
waveguide
care of, 5-2
cleaning, 5-2
waveguide module
description of, 2-7
weight
system, 3-7
system components, 3-7
weight and dimensions
system, 3-7
system components, 3-7

This information is subject to change without notice.
© Keysight Technologies 2012 - 2015
January 2015



N5251-90001
www.keysight.com